

TESY

It's impressive



PRO

PROFI LINE PRODUCTS



About TESI

TESI OOD is founded in 1990 and is part of Ficosota holding. The company has five factories – three in Shumen and two in Smyadovo. TESI is the largest Bulgarian and one of the leading European producers of electric storage water heaters, indirectly heated water tanks and electric heating appliances.

In the last decade TESI showed a rapid development and introduced to the world a wide range of cutting-edge products and patented solutions that meet the current requirements in terms of energy efficiency, reducing resource consumption and environmental protection.

The company continues its development by increasing its production capacity and launching new product lines.

TESI in numbers

Sales in over **50 countries on 4 continents**

840 employees

5 factories

Top **4 producer** of electric water heaters and heating appliances in Europe

3 main product categories – electric water heaters, electric heating appliances, combined and indirectly heated storage water tanks

TESI indirectly heated water tanks in numbers and facts

<0.2% - defectives in the warranty period

>25% - annual growth in production and sales

70 000 - annual production capacity

Class "A" - innovative energy saving products

	page
Combined and indirectly heated storage tanks	4
“All in one” heat pump and storage tank for domestic hot water production	4
Storage tanks for domestic hot water energy efficiency Class A	7
Floor standing storage tanks	11
Floor standing storage tanks with high output heat exchanger	16
Floor standing storage tanks for use with Gas boiler	20
Buffer tanks for domestic hot water	22
Mixing vessel	26
Buffer tanks for active cooling systems	28
Buffer tanks for heating systems	31
Combined storage tanks for heating systems and domestic hot water production via hygienic coil	38
Combined storage tanks for heating systems and domestic hot water - tank in tank	42
Accessories	46
Solar thermal sets	49

Combined and indirectly heated storage tanks

"All in one" heat pump and storage tank for domestic hot water production



"All in one" heat pump and storage tank for domestic hot water production | 200 to 260 litres

MODEL		EVHP 9S 200 60	EVHP 200 60	EVHP 9S 260 60	EVHP 260 60
Art. number	N°	422363	422361	422320	422360
Total thermal power	kW	3.1	3.1	3.1	3.1
Heating time ⁽¹⁾	h:m	07:16	07:16	09:44	09:44
Heating time in BOOST mode ⁽¹⁾	h:m	03:48	03:48	04:57	04:57
Heat losses 65°C ⁽²⁾	W	76	76	105	105
Declared load profile		L	L	XL	XL
Water heating energy efficiency class under average climate conditions		A			
Water heating energy efficiency in % under average climate conditions	%	110	110	121	121
Annual electricity consumption in kWh under average climate conditions	kWh	929	929	1384	1384
Electrical data					
Power supply	V	1 / N / 230			
Frequency	Hz	50			
Degree of protection		IPX4			
HP maximum absorption	kW	0.5			
Average absorption	kW	0.37			
Heating element + HP maximum absorption	kW	2.0			
Electric heating element power	kW	1.5			
Maximum current in HP	A	2.3			
Required overload protections	A	16 A T fuse/ 16 A automatic switch, characteristic C (to be expected during installation on power supply systems)			
Internal protection		Single safety thermostat with manual reset on a resistive element			
Operating conditions					
Min. ÷ max temperature heat pump air intake (90% R.H.)	°C	4÷43			
Min. ÷ max temperature installation site	°C	4÷43			
Working temperature					
HP Maximum settable temperature - ECO cycle	°C	56			
Maximum settable temperature in an AUTOMATIC cycle	°C	70			
Compressor		Rotary			
Compressor protection		Thermal circuit breaker with automatic reset			
Thermodynamic circuit protection type		Safety pressure switch with automatic reset			
Fan		Centrifugal			
Ejection outlet diameter	mm	160			
Revolutions per minute	rpm	1420			
Nominal air capacity	m ³ /h	350			
Max. pressure head available	Pa	100			
Motor protection		Internal thermal circuit breaker with automatic reset			
Condenser		Wrapped externally, not in contact with water			
Coolant		R134a			
Load	g	900			
Water storage					
Water storage capacity	l	200	200	260	260
Max. quantity of hot water that can be used V _{max} ⁽³⁾	l	276	276	342	342
Coil for connection to solar thermal power system	m ²	0.96	N/A	0.96	N/A
Coil for connection to an auxiliary heating source	m ²	N/A	N/A	N/A	N/A
Cathodic protection		2 x Mg anode Ø 32x260 mm			
Insulation		50 mm rigid PU			
Defrosting		Passive with air			
Transport weight	kg	94	90	110.2	91.5
Sound power L _w (A) ⁽⁴⁾	dB(A)	59			
Automatic anti-Legionella disinfection cycle ⁽⁵⁾		YES			
Maximum working pressure	bar	7			

(1) - temperature of incoming air supply 20 (max. 15°C), temperature of boiler storage environment 20°C, water heated from 10°C to 55°C, (according to UNI EN 16147-2011)

(2) - measurements carried out according to UNI EN 12897-2006

(3) - measurements carried out according to UNI EN 16147-2011

(4) - measurements carried out according to EN 12102-2013

(5) - Automatic activation every 30 days of operation

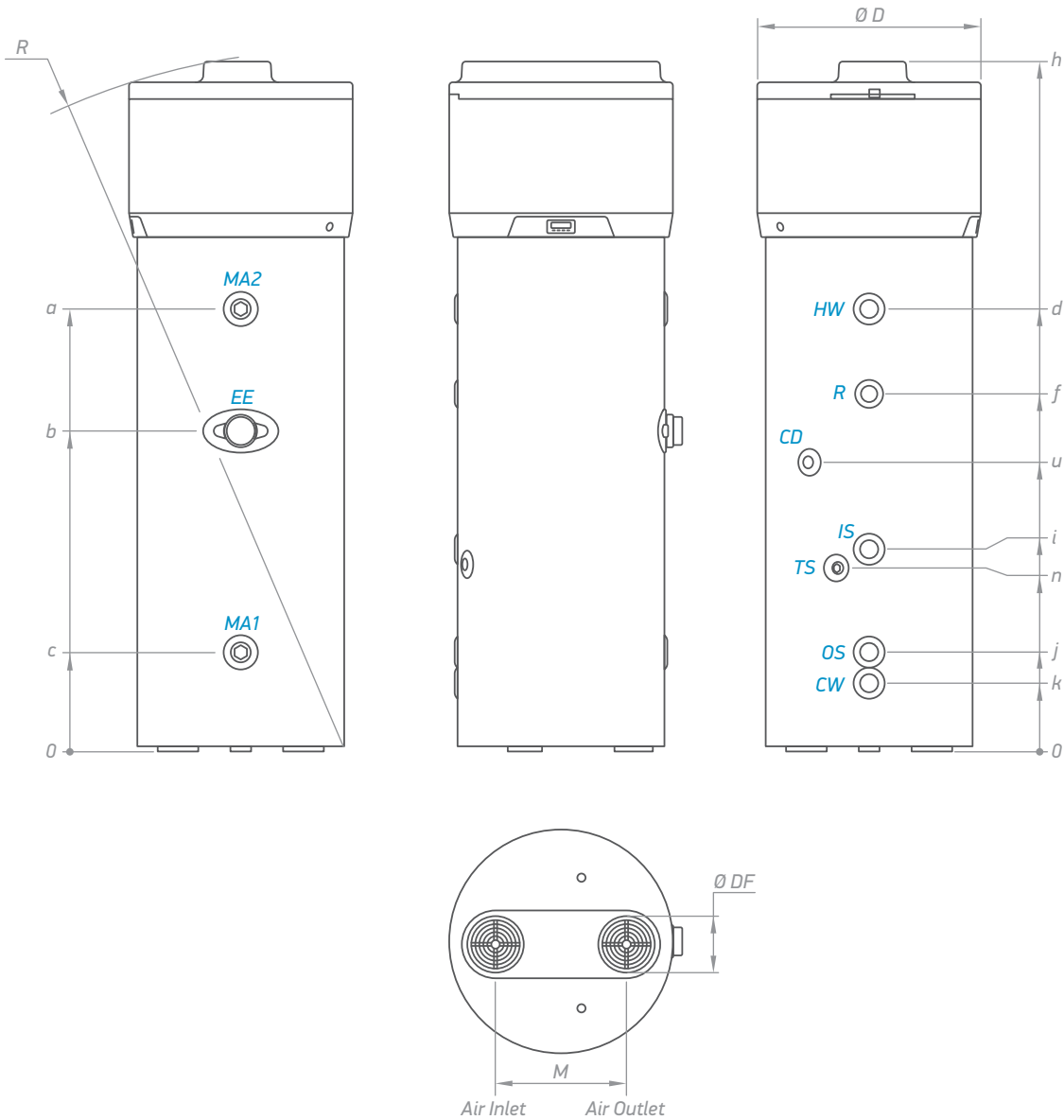

Dimensions ±5 mm	EVHP 9S 200 60	EVHP 200 60	EVHP 9S 260 60	EVHP 260 60	
h	mm	1714	1714	2004	2004
a	mm	1000	1000	1286	1286
b	mm	716	716	931	931
c	mm	287	287	287	287
d	mm	1001	1001	1286	1286
f	mm	769	769	1065	1065
i	mm	674	674	674	674
j	mm	287	287	287	287
k	mm	202	202	202	202
n	mm	644	644	644	644
u	mm	769	769	839	839
R	mm	1751	1751	2038	2038
M	mm	380	380	380	380
DF	mm	160	160	160	160
ØD	mm	650	650	650	650

	EVHP 9S 200 60 EVHP 9S 260 60	EVHP 200 60 EVHP 260 60
CW	- cold water inlet	G 1"
HW	- hot water outlet	G 1"
IS	- inlet heat exchanger	G 1"
OS	- outlet heat exchanger	G 1"
TS	- thermo pocket	G ½"
R	- recirculation	G ¾"
EE	- electric heating element	
CD	- condensate drainage	G ½"

Thread designations according to EN ISO 228-1!

Combined and indirectly heated storage tanks

Storage tanks for domestic hot water energy efficiency Class A

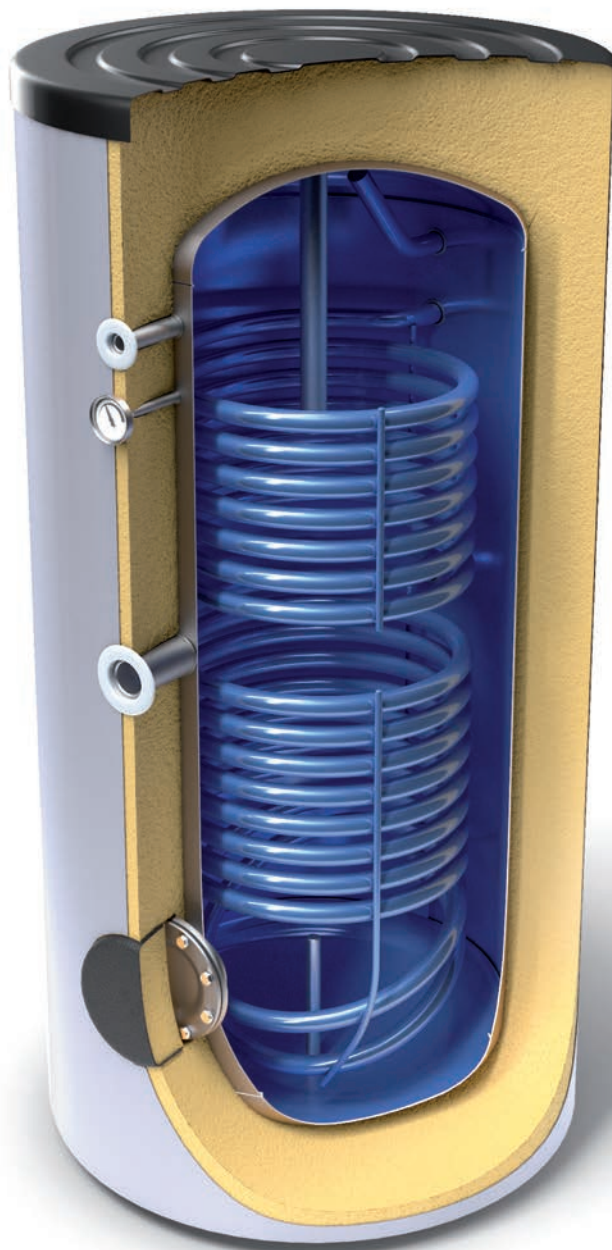

MODEL		EV 200 65	EV 300 75
Art. number	Nº	302732	302730
Capacity	L	200	300
Net weight	kg	48	69
Insulation (rigid PU)	mm	75	100
Heat losses ΔT 45K	kWh/24h	1.05	1.1
Energy efficiency class		A	A
Maximum operational temperature	°C	95	95
Rated pressure	bar	8	8
Thermo pockets	pieces	3	3

Dimensions ± 5 mm			
h	mm	1247	1495
a	mm	993	1207
b	mm	714	846
c	mm	314	314
d	mm	993	1207
f	mm	771	1010
k	mm	199	203
R	mm	1345	1563
$\varnothing C$	mm	650	750
$\varnothing D$	mm	500	550

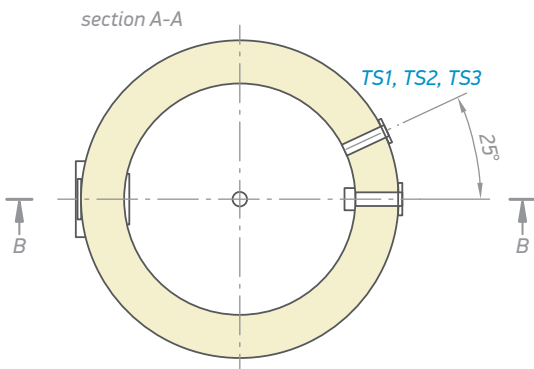
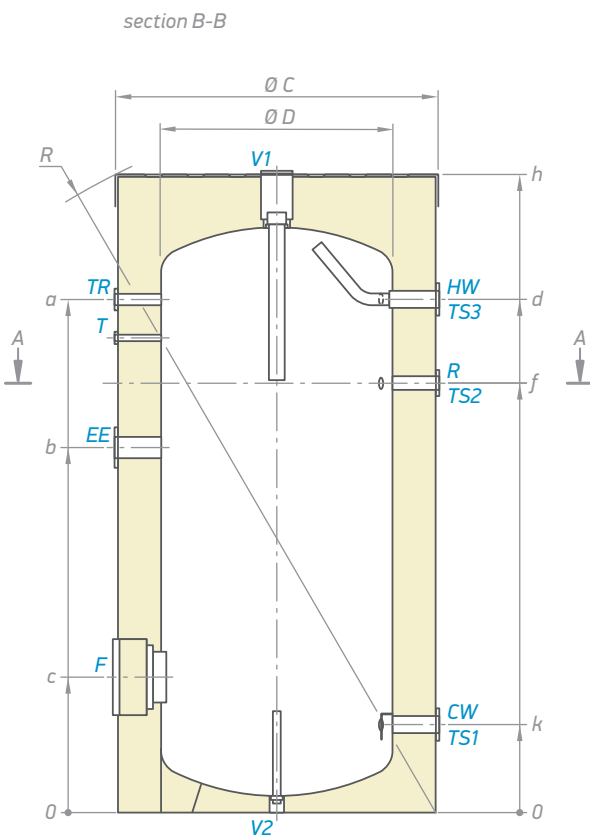

EV 200 65
EV 300 75

CW	- cold water inlet	G 1"
HW	- hot water outlet	G 1"
TS1	- thermo pocket level 1	G 1/2"
TS2	- thermo pocket level 2	G 1/2"
TS3	- thermo pocket level 3	G 1/2"
R	- recirculation	G 3/4"
EE	- opening for electric element	G 1 1/2"
T	- thermometer	$\varnothing 14 \times 1.5$
TR	- opening for thermoregulator	G 1/2"

Thread designations according to EN ISO 228-1!

MODEL		EV 9 S 200 65	EV 12 S 300 75
Art. number		302733	302731
Capacity	L	200	300
Net weight	kg	68	95
Insulation (rigid PU)	mm	75	100
Heat exchanger surface S1	m ²	0.96	1.45
Heat exchanger capacity S1	L	5.8	8.8
Exchanged power in continuous mode (max coil output) S1 *60-80/70-90°C	kW	32 / 40	40 / 53
Continuous flow rate of DHW at ΔT 35°C (S1) *60-80/70-90°C	L/h	768 / 955	882 / 1248
Maximum quantity of drawn off water MIX 45°C (**15-60°C), Power input cut off (S1)	L	240	330
Heat losses ΔT 45K	kWh/24h	1.05	1.1
Energy efficiency class		A	A
Maximum operational temperature	°C	95	95
Rated pressure of the water tank	bar	8	8
Rated pressure of the heat exchanger	bar	6	6
NL factor S1		4.3	8.1
Minimum time of heating S1 *80°C-**15/60°C	min	38	40
Thermo pocket	pieces	1	1

* - outlet - inlet temperature of the heat transfer fluid

** - 15°C - cold water temperature, 60°C - hot water temperature (domestic water)

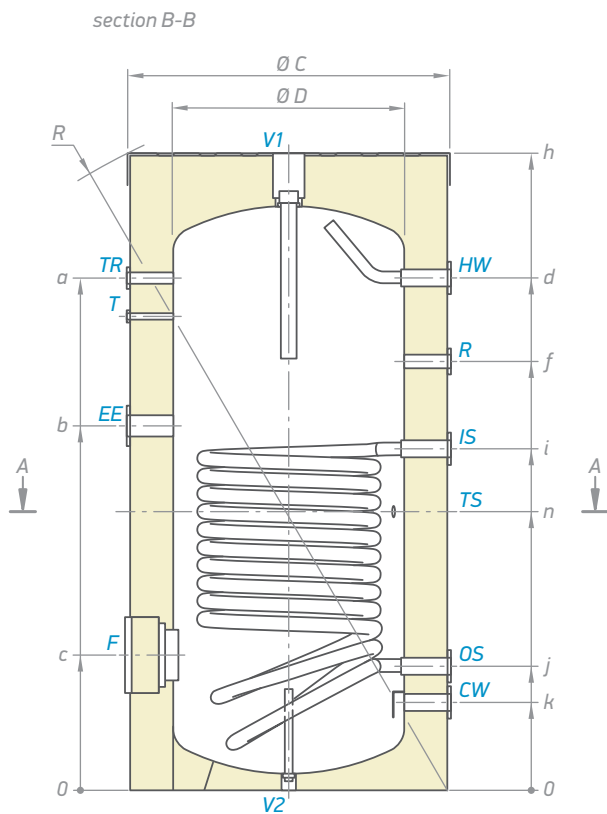

Dimensions ±5 mm			
h	mm	1274	1495
a	mm	993	1207
b	mm	714	846
c	mm	314	314
d	mm	993	1207
f	mm	771	1010
i	mm	671	804
j	mm	284	288
k	mm	199	203
n	mm	564	653
R	mm	1345	1563
Ø C	mm	650	750
Ø D	mm	500	550

section A-A

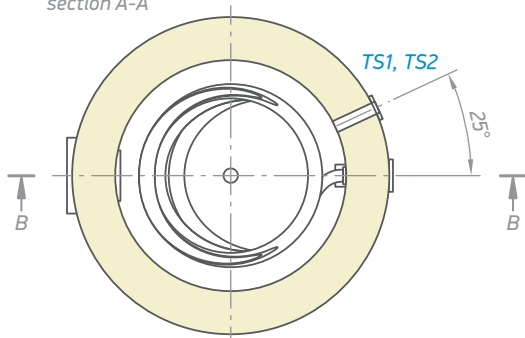

EV 9 S 200 65
EV 12 S 300 75

CW	- cold water inlet	G 1"
HW	- hot water outlet	G 1"
IS	- solar flow	G 1"
OS	- solar return	G 1"
TS	- thermo pocket	G ½"
R	- recirculation	G ¾"
EE	- opening for electric element	G 1½"
T	- thermometer	Ø 14 x 1.5
TR	- opening for thermoregulator	G ½"

Thread designations according to EN ISO 228-1!

MODEL		EV 7/5 S2 200 65	EV 10/7 S2 300 75
Art. number	Nº	302653	302654
Capacity	L	200	294
Net weight	kg	73	103
Insulation (rigid PU)	mm	75	100
Heat exchanger surface S1	m ²	0.75	1.21
Heat exchanger surface S2	m ²	0.54	0.85
Heat exchanger capacity S1	L	4.6	7.4
Heat exchanger capacity S2	L	3.3	5.2
Exchanged power in continuous mode (max coil output) S1 *60-80 / 70-90°C	kW	23 / 30	34 / 46
Exchanged power in continuous mode (max coil output) S2 *60-80 / 70-90°C	kW	13 / 20	25 / 33
Continuous flow rate of DHW at ΔT 35°C (S1) *60-80 / 70-90°C	L/h	558 / 648	792 / 1092
Continuous flow rate of DHW at ΔT 35°C (S2) *60-80 / 70-90°C	L/h	318 / 468	594 / 785
Maximum quantity of drawn off water MIX 45°C (**15-60°C), Power input cut off (S1)	L	225	302
Maximum quantity of drawn off water MIX 45°C (**15-60°C), Power input cut off (S2)	L	111	151
Heat losses ΔT 45K	kWh/24h	1.05	1.1
Energy efficiency class		A	A
Maximum operational temperature	°C	95	95
Rated pressure	bar	8	8
Rated pressure of the heat exchanger	bar	6	6
NL factor S1		4.1	8
NL factor S2		1	1.4
Minimum time of heating S1 *80°C-**15/60°C	min	39	40
Minimum time of heating S2 *80°C-**15/60°C	min	39	39
Thermo pockets	pieces	2	2

* - outlet - inlet temperature of the heat transfer fluid

** - 15°C - cold water temperature, 60°C - hot water temperature (domestic water)

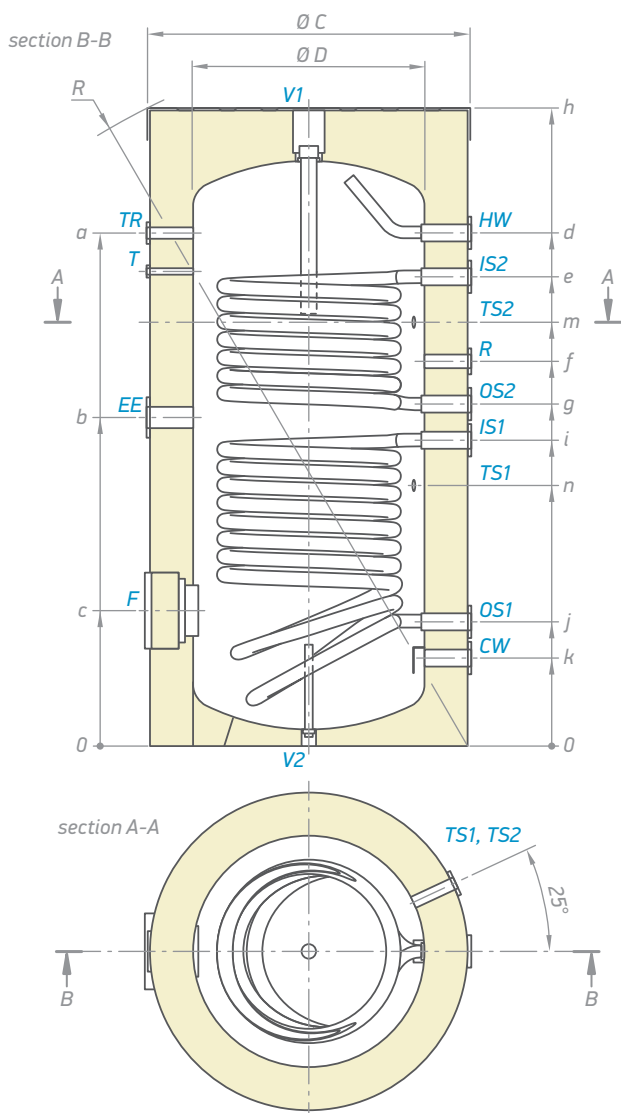

Dimensions ±5 mm			
h	mm	1274	1495
a	mm	993	1207
b	mm	628	760
c	mm	314	314
d	mm	993	1207
e	mm	886	1104
f	mm	746	903
g	mm	671	803
i	mm	585	718
j	mm	284	288
k	mm	199	203
m	mm	815	996
n	mm	478	610
R	mm	1345	1563
Ø C	mm	650	750
Ø D	mm	500	550

EV 7/5 S2 200 65
EV 10/7 S2 300 75

CW	- cold water inlet	G 1"
HW	- hot water outlet	G 1"
IS1	- solar flow	G 1"
IS2	- central heating flow	G 1"
OS1	- solar return	G 1"
OS2	- central heating return	G 1"
TS1	- thermo pocket level 1	G ½"
TS2	- thermo pocket level 2	G ½"
R	- recirculation	G ¾"
EE	- opening for electric element	G 1½"
T	- thermometer	Ø 14 x 1.5
TR	- opening for thermoregulator	G ½"

Thread designations according to EN ISO 228-1!

Combined and indirectly heated storage tanks

Floor standing storage tanks



MODEL		EV 9S 160 60	EV 9S 200 60	EV 12S 300 65	EV 11S 400 75	EV 15S 500 75
Art. number	Nº	301408	301409	301394	301392	301395
Capacity	L	160	200	300	400	500
Net weight	kg	54	65	92	137	145
Insulation (rigid PU)	mm	50	50	50	50	50
Heat exchanger surface S1	m ²	0.96	0.96	1.45	1.65	2.25
Heat exchanger surface S2	m ²	-	-	-	-	-
Heat exchanger capacity S1	L	5.8	5.8	8.8	10	13.7
Heat exchanger capacity S2	L	-	-	-	-	-
Exchanged power in continuous mode (max coil output) S1 *60-80 / 70-90°C	kW	31 / 39	32 / 40	40 / 53	47 / 61	61 / 73
Exchanged power in continuous mode (max coil output) S2 *60-80 / 70-90°C	kW	-	-	-	-	-
Continuous flow rate of DHW at ΔT 35°C (S1) *60-80 / 70-90°C	L/h	720 / 1020	768 / 955	882 / 1248	1002 / 1500	1500 / 1795
Continuous flow rate of DHW at ΔT 35°C (S2) *60-80 / 70-90°C	L/h	-	-	-	-	-
Maximum quantity of drawn off water MIX 45°C (**15-60°C), Power input cut off (S1)	L	180	240	330	412	553
Maximum quantity of drawn off water MIX 45°C (**15-60°C), Power input cut off (S2)	L	-	-	-	-	-
Heat losses ΔT 45K	kWh/24h	1.2	1.4	1.7	2.2	2.3
Energy efficiency class	B	B	B	C	C	
Maximum operational temperature	°C	95	95	95	95	95
Rated pressure	bar	8	8	8	8	8
Rated pressure of the heat exchanger	bar	6	6	6	6	6
NL factor S1	-	-	4.3	8.1	12	19
NL factor S2	-	-	-	-	-	-
Minimum time of heating S1 *80°C-**15/60°C	min	31	38	40	41	41
Minimum time of heating S2 *80°C-**15/60°C	min	-	-	-	-	-
Thermo pockets	pieces	1	1	1	1	1

* - outlet - inlet temperature of the heat transfer fluid

** - 15°C - cold water temperature, 60°C - hot water temperature (domestic water)

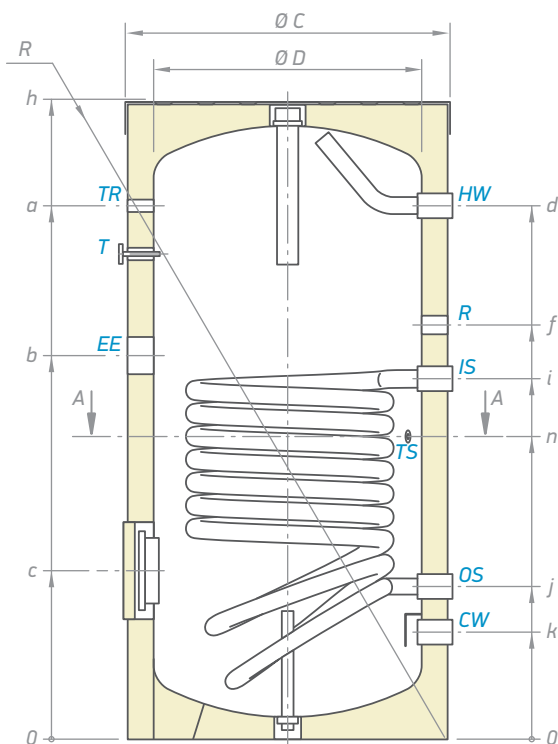

Dimensions ±5 mm						
h	mm	1007	1200	1420	1407	1674
a	mm	785	993	1207	1156	1448
b	mm	-	714	846	813	986
c	mm	314	314	314	331	324
d	mm	785	993	1207	1156	1448
f	mm	602	771	1010	945	1199
i	mm	671	671	804	775	944
j	mm	284	284	288	302	299
k	mm	200	199	203	220	214
n	mm	360	564	653	617	750
R	mm	1169	1345	1563	1596	1838
Ø C	mm	600	600	650	750	750
Ø D	mm	500	500	550	650	650

EV 9 S 160 60
 EV 9 S 200 60
 EV 12 S 300 65
 EV 11 S 400 75
 EV 15 S 500 75

CW	- cold water inlet	G 1"
HW	- hot water outlet	G 1"
IS	- solar flow	G 1"
OS	- solar return	G 1"
TS	- thermo pocket	G ½"
R	- recirculation	G ¾"
EE	- opening for electric element	G 1½"
T	- thermometer	Ø 14 x 1.5
TR	- opening for thermoregulator	G ½"

Thread designations according to EN ISO 228-1!

MODEL		EV 12S 800 95 F43 TP-C	EV 13S 1000 101 F44 TP-C	EV 12S 1500 120 F45 TP-C	EV 15S 2000 130 F46 TP-C
Art. number	Nº	303824	303828	303823	303832
Capacity	L	800	988	1500	1951
Net weight	kg	221	233	371	442
Insulation	mm	80	80	100	100
Heat exchanger surface S1	m ²	2.89	3.45	3.3	4.5
Heat exchanger surface S2	m ²	-	-	-	-
Heat exchanger capacity S1	L	26.2	31.3	30.4	41.6
Heat exchanger capacity S2	L	-	-	-	-
Exchanged power in continuous mode (max coil output) S1 *60-80 / 70-90°C	kW	79.8 / 103.7	95.2 / 123.8	140 / 175	198 / 250
Exchanged power in continuous mode (max coil output) S2 *60-80 / 70-90°C	kW	-	-	-	-
Continuous flow rate of DHW at ΔT 35°C (S1) *60-80 / 70-90°C	L/h	1963.1 / 2551	2341.9 / 3045.5	3450 / 4330	4874 / 6160
Continuous flow rate of DHW at ΔT 35°C (S2) *60-80 / 70-90°C	L/h	-	-	-	-
Maximum quantity of drawn off water MIX 45°C (**15-60°C), Power input cut off (S1)	L	845	1081	1660	2387
Maximum quantity of drawn off water MIX 45°C (**15-60°C), Power input cut off (S2)	L	-	-	-	-
Heat losses ΔT 45K	kWh/24h	3.1	3.4	3.8	4.4
Energy efficiency class		C	C	C	C
Maximum operational temperature	°C	95	95	95	95
Rated pressure	bar	8	8	8	8
Rated pressure of the heat exchanger	bar	6	6	6	6
NL factor S1		30	41	70	94
NL factor S2		-	-	-	-
Minimum time of heating S1 *80°C-**15/60°C	min	40	46	45	57
Minimum time of heating S2 *80°C-**15/60°C	min	-	-	-	-
Thermo pockets	pieces	2	2	2	2

* - outlet - inlet temperature of the heat transfer fluid

** - 15°C - cold water temperature, 60°C - hot water temperature (domestic water)

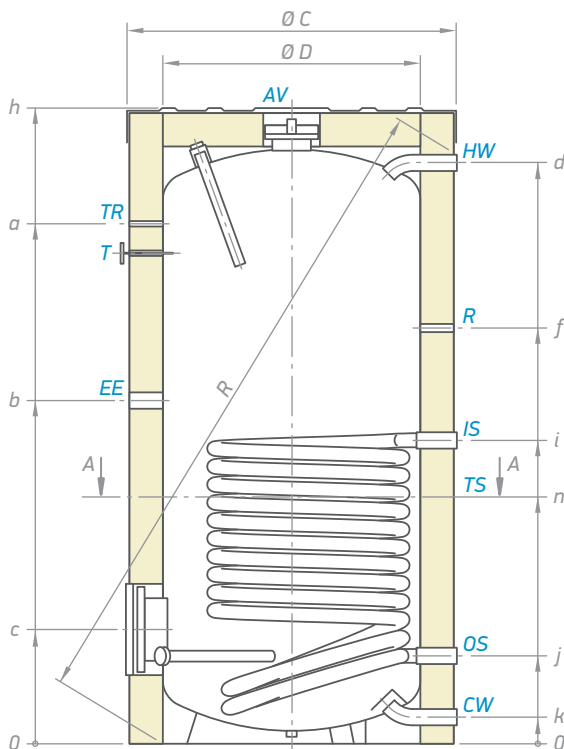

section A-A

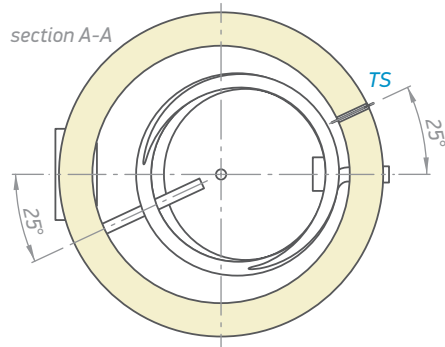

Dimensions ±5 mm					
h	mm	1937	2002	2193	2399
a	mm	1592	1475	1768	1927
b	mm	1051	1132	1168	1298
c	mm	351	354	468	497
d	mm	1780	1846	2061	2246
f	mm	1273	1274	1378	1551
i	mm	929	987	1081	1235
j	mm	269	272	421	411
k	mm	82.5	81.5	90	90
n	mm	756	830	579	578
R	mm	2012	2097	2361	2592
Ø C	mm	950	1010	1200	1300
Ø D	mm	790	850	1000	1100

EV 12S 800 95 F43 TP-C
EV 13S 1000 101 F44 TP-C

EV 12S 1500 120 F45 TP-C
EV 15S 2000 130 F46 TP-C

CW	- cold water inlet	G 1½" B	G 2" B
HW	- hot water outlet	G 1½" B	G 2" B
IS	- solar flow	G 1½" B	G 1½" B
OS	- solar return	G 1½" B	G 1½" B
TS	- thermo pocket	G ½"	G ½"
R	- recirculation	G ¾"	G 1½"
EE	- opening for electric element	G 1½"	G 1½"
T	- thermometer	Ø 14 x 1.5	Ø 14 x 1.5
TR	- opening for thermoregulator	G ½"	G ½"
AV	- opening for air ventilation	G ¾"	G ¾"

Thread designations according to EN ISO 228-1!

MODEL		EV 6/4 S2 160 60	EV 7/5 S2 200 60	EV 10/7S2 300 65	EV 11/5 S2 400 75	EV 15/7S2 500 75
Art. number	Nº	302165	301407	301391	301393	301396
Capacity	L	160	200	294	400	500
Net weight	kg	66	70	100	146	158
Insulation (rigid PU)	mm	50	50	50	50	50
Heat exchanger surface S1	m ²	0.61	0.75	1.21	1.65	2.25
Heat exchanger surface S2	m ²	0.43	0.54	0.85	0.76	1.06
Heat exchanger capacity S1	L	3.6	4.6	7.4	10	13.7
Heat exchanger capacity S2	L	2.6	3.3	5.2	4.6	6.4
Exchanged power in continuous mode (max coil output) S1 *60-80 / 70-90°C	kW	20 / 14	23 / 30	34 / 46	47 / 61	61 / 73
Exchanged power in continuous mode (max coil output) S2 *60-80 / 70-90°C	kW	10 / 7	13 / 20	25 / 33	21 / 30	35 / 47
Continuous flow rate of DHW at ΔT 35°C (S1) *60-80 / 70-90°C	L/h	660	558 / 648	792 / 1092	1002 / 1500	1500 / 1795
Continuous flow rate of DHW at ΔT 35°C (S2) *60-80 / 70-90°C	L/h	480	318 / 468	594 / 785	470 / 648	785 / 1002
Maximum quantity of drawn off water MIX 45°C (**15-60°C), Power input cut off (S1)	L	8/(6)	225	302	405	510
Maximum quantity of drawn off water MIX 45°C (**15-60°C), Power input cut off (S2)	L	4/(3)	111	151	200	250
Heat losses ΔT 45K	kWh/24h	1.2	1.4	1.7	2.2	2.3
Energy efficiency class		B	B	B	C	C
Maximum operational temperature	°C	95	95	95	95	95
Rated pressure	bar	8	8	8	8	8
Rated pressure of the heat exchanger	bar	6	6	6	6	6
NL factor S1			4,1	8	12	18
NL factor S2			1	1,4	2	3
Minimum time of heating S1 *80°C-**15/60°C	min	30	39	40	41	42
Minimum time of heating S2 *80°C-**15/60°C	min	30	39	39	39	39
Thermo pockets	pieces	2	2	2	2	2

* - outlet - inlet temperature of the heat transfer fluid

** - 15°C - cold water temperature, 60°C - hot water temperature (domestic water)

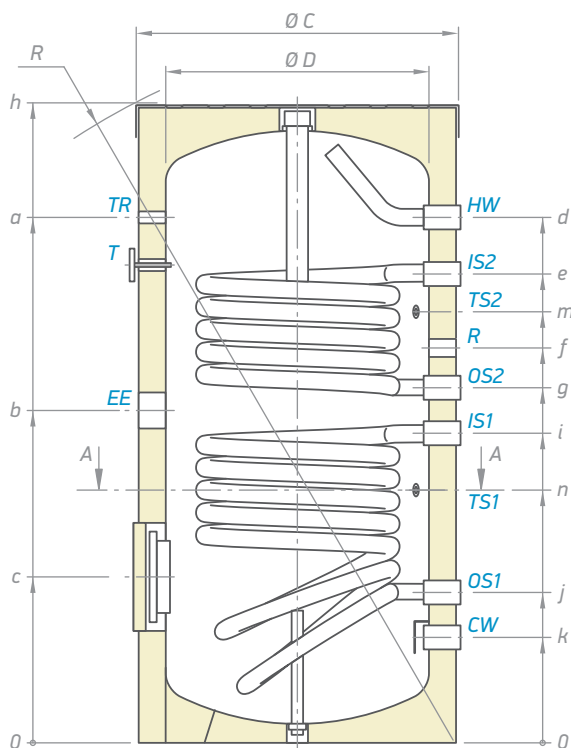

Dimensions ±5 mm						
h	mm	1007	1200	1420	1407	1674
a	mm	785	993	1207	1156	1448
b	mm	519	628	760	813	986
c	mm	279	314	314	331	324
d	mm	788	993	1207	1156	1448
e	mm	741	886	1104	1073	1330
f	mm	-	746	903	943	1165
g	mm	569	671	803	858	1029
i	mm	475	585	718	775	944
j	mm	204	284	288	302	299
k	mm	204	199	203	220	214
m	mm	-	815	996	998	1265
n	mm	349	478	610	617	750
R	mm	649	1345	1563	1596	1838
Ø C	mm	600	600	650	750	750
Ø D	mm	500	500	550	650	650

EV 6/4 S2 160 60
 EV 7/5 S2 200 60
 EV 10/7S2 300 65
 EV 11/5 S2 400 75
 EV 15/7S2 500 75

CW	- cold water inlet	G 1"
HW	- hot water outlet	G 1"
IS1	- solar flow	G 1"
IS2	- central heating flow	G 1"
OS1	- solar return	G 1"
OS2	- central heating return	G 1"
TS1	- thermo pocket level 1	G ½"
TS2	- thermo pocket level 2	G ½"
R	- recirculation	G ¾"
EE	- opening for electric element	G 1½"
T	- thermometer	Ø 14 x 1.5
TR	- opening for thermoregulator	G ½"

Thread designations according to EN ISO 228-1!

MODEL		EV 12/9S2 800 95 F43 TP2-C	EV 13/7S2 1000 101 F44 TP2-C	EV 12/8 S2 1500 120 F45 TP2-C	EV 15/9 S2 2000 130 F46 TP2-C
Art. number	Nº	303827	303831	303826	303833
Capacity	L	800	981	1488	1918
Net weight	kg	252	279	408	486
Insulation	mm	80	80	100	100
Heat exchanger surface S1	m ²	2.89	3.45	3.3	4.5
Heat exchanger surface S2	m ²	1.54	1.31	2.3	2.75
Heat exchanger capacity S1	L	26.2	31.3	30.4	41.6
Heat exchanger capacity S2	L	9.4	7.9	20.5	25.2
Exchanged power in continuous mode (max coil output) S1 *60-80 / 70-90°C	kW	79.8 / 103.7	95.2 / 123.8	140 / 175	198 / 250
Exchanged power in continuous mode (max coil output) S2 *60-80 / 70-90°C	kW	45 / 55.3	36.2 / 47	95 / 120	108 / 142
Continuous flow rate of DHW at ΔT 35°C (S1) *60-80 / 70-90°C	L/h	1963.1 / 2551	2341.9 / 3045.5	3450 / 4330	4874 / 6160
Continuous flow rate of DHW at ΔT 35°C (S2) *60-80 / 70-90°C	L/h	1107 / 1360.4	890.5 / 1156.2	2349 / 2970	2658 / 3509
Maximum quantity of drawn off water MIX 45°C (**15-60°C), Power input cut off (S1)	L	823	1055	1660	2387
Maximum quantity of drawn off water MIX 45°C (**15-60°C), Power input cut off (S2)	L	401	503	611	806
Heat losses ΔT 45K	kWh/24h	3.1	3.4	3.8	4.4
Energy efficiency class	C	C	C	C	C
Maximum operational temperature	°C	95	95	95	95
Rated pressure	bar	8	8	8	8
Rated pressure of the heat exchanger	bar	6	6	6	6
NL factor S1		29	40	70	94
NL factor S2		12	19	18	31
Minimum time of heating S1 *80°C-**15/60°C	min	40	46	45	57
Minimum time of heating S2 *80°C-**15/60°C	min	39	41	30	35
Thermo pockets	pieces	2	2	2	2

* - outlet - inlet temperature of the heat transfer fluid

** - 15°C - cold water temperature, 60°C - hot water temperature (domestic water)

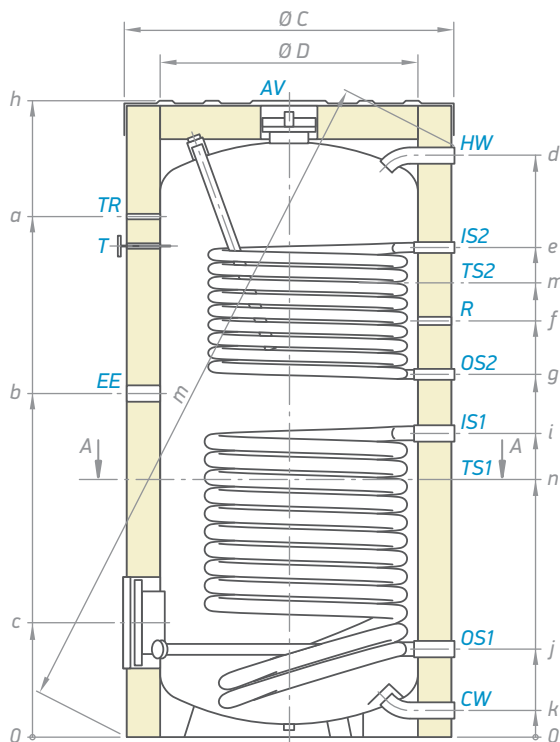

section A-A

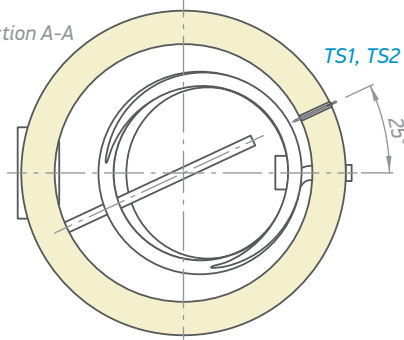

Dimensions ±5 mm					
h	mm	1937	2002	2193	2399
a	mm	1592	1475	1768	1927
b	mm	1051	1132	1168	1287
c	mm	351	354	468	497
d	mm	1778	1847	2061	2263
e	mm	1492	1475	1691	1875
f	mm	1273	1274	1378	1560
g	mm	1105	1174	1251	1380
i	mm	929	987	1081	1244
j	mm	269	272	421	420
k	mm	82.5	81.5	90	90
m	mm	1363	1374	1329	1537
n	mm	756	817	579	587
R	mm	2014	2100	2361	2565
Ø C	mm	950	1010	1200	1300
Ø D	mm	790	850	1000	1100

EV 12/9S2 800 95 F43 TP2-C

EV 13/7S2 1000 101 F44 P2-C

EV 13/7S2 1000 101 F44 P2-C

EV 15/9 S2 2000 130 F46 P2-C

CW	- cold water inlet	G 1½" B	G 2" B
HW	- hot water outlet	G 1½" B	G 2" B
IS1	- solar flow	G 1½" B	G 1½" B
IS2	- central heating flow	G 1" B	G 1½" B
OS1	- solar return	G 1½" B	G 1½" B
OS2	- central heating return	G 1" B	G 1½" B
TS1	- thermo pocket level 1	G ½"	G ½"
TS2	- thermo pocket level 2	G ½"	G ½"
R	- recirculation	G ¾"	G 1½"
EE	- opening for electric element	G 1½"	G 1½"
T	- thermometer	Ø 14 x 1.5	Ø 14 x 1.5
TR	- opening for thermoregulator	G ½"	G ½"
AV	- opening for air ventilation	G ¾"	G ¾"

Thread designations according to EN ISO 228-1!

Combined and indirectly heated storage tanks

Floor standing storage tanks with high output heat exchanger



MODEL		EV 17S 300 65	EV 17S 400 75	EV 23S 500 75
Art. number	Nº	301397	301398	301400
Capacity	L	300	400	495
Net weight	kg	102	128	152
Insulation (rigid PU)	mm	50	50	50
Heat exchanger surface S1	m ²	2.1	2.55	3.4
Heat exchanger capacity S1	L	12.6	15.5	23.3
Exchanged power in continuous mode (max coil output) S1 *60-80 / 70-90°C	kW	58 / 79	72 / 98	100 / 135
Continuous flow rate of DHW at ΔT 35°C (S1) *60-80 / 70-90°C	L/h	1422 / 1932	1776 / 2400	2448 / 3306
Maximum quantity of drawn off water MIX 45°C (**15-60°C), Power input cut off (S1)	L	302	412	553
Heat losses ΔT 45K	kWh/24h	1.7	2.2	2.3
Energy efficiency class		B	C	C
Maximum operational temperature	°C	95	95	95
Maximum operational temperature of heat exchanger	°C	110	110	110
Rated pressure	bar	8	8	8
Rated pressure of the heat exchanger	bar	6	6	6
Thermo pockets	pieces	3	3	3

* - outlet - inlet temperature of the heat transfer fluid

** - 15°C - cold water temperature, 60°C - hot water temperature (domestic water)

Dimensions ±5 mm				
h	mm	1420	1400	1670
c	mm	371	411	405
d	mm	1184	1168	1447
f	mm	953	960	1161
i	mm	1101	1120	1378
k	mm	205	225	225
l	mm	1055	1059	1161
m	mm	691	778	680
n	mm	398	448	467
R	mm	1560	1590	1833
Ø C	mm	650	750	750
Ø D	mm	550	650	650

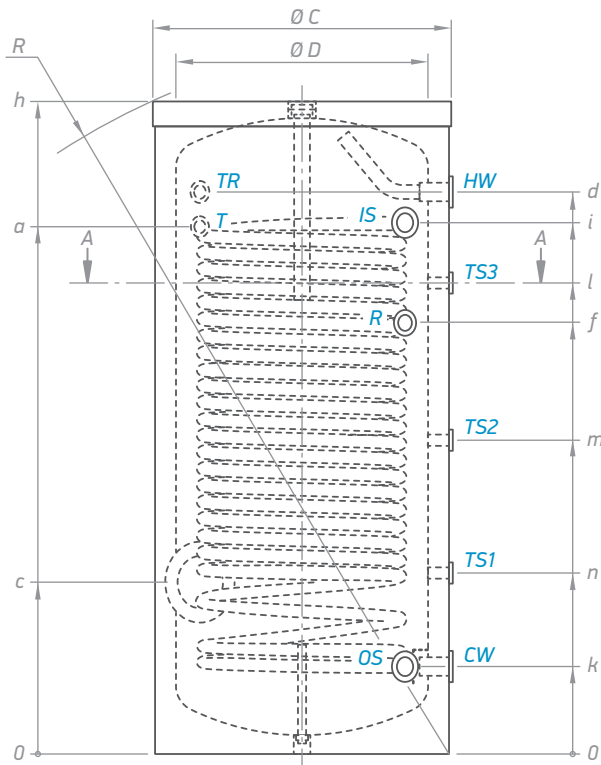

section A-A

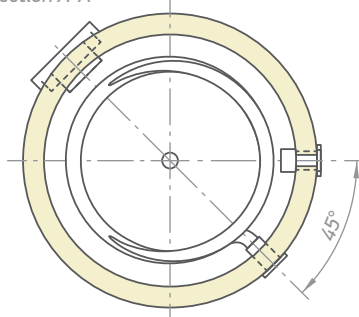

EV 17S 300 65
EV 17S 400 75
EV 23S 500 75

CW	- cold water inlet	G 1"
HW	- hot water outlet	G 1"
IS	- heat exchanger inlet	G 1"
OS	- heat exchanger outlet	G 1"
R	- recirculation	G ¾"
T	- thermometer	Ø 14 x 1.5
TR	- opening for thermoregulator	G ½"
TS1	- thermo pocket level 1	G ½"
TS2	- thermo pocket level 2	G ½"
TS3	- thermo pocket level 3	G ½"

Thread designations according to EN ISO 228-1!

MODEL		EV 2x12S 200 60	EV 2x15S 300 65	EV 2x23S 500 75
Art. number	Nº	302166	301401	302167
Capacity	L	196	285	475
Net weight	kg	85	112	182
Insulation (rigid PU)	mm	50	50	50
Heat exchanger surface S1	m ²	2.1	3	6
Heat exchanger capacity S1	L	12.5	18.3	33
Exchanged power in continuous mode (max coil output) S1 *60-80 / 70-90°C	kW	51 / 69	91 / 123	138 / 186
Continuous flow rate of DHW at ΔT 35°C (S1) *60-80 / 70-90°C	L/h	1266 / 1704	2238 / 3018	3390 / 4566
Maximum quantity of drawn off water MIX 45°C (**15-60°C), Power input cut off (S1)	L	282	450	750
Heat losses ΔT 45K	kWh/24h	1.4	1.7	2.3
Energy efficiency class		B	B	C
Maximum operational temperature	°C	95	95	95
Maximum operational temperature of heat exchanger	°C	110	110	110
Rated pressure	bar	8	8	8
Rated pressure of the heat exchanger	bar	6	6	6
Thermo pockets	pieces	3	3	3

* - outlet - inlet temperature of the heat transfer fluid

** - 15°C - cold water temperature, 60°C - hot water temperature (domestic water)

Dimensions ±5 mm				
h	mm	1202	1420	1670
a	mm	996	1184	1447
c	mm	264	278	282
d	mm	996	1184	1447
i	mm	792	937	1303
k	mm	202	205	225
l	mm	897	1055	1162
m	mm	633	691	864
n	mm	360	398	467
R	mm	1345	1560	1823
∅ C	mm	600	650	750
∅ D	mm	500	550	650

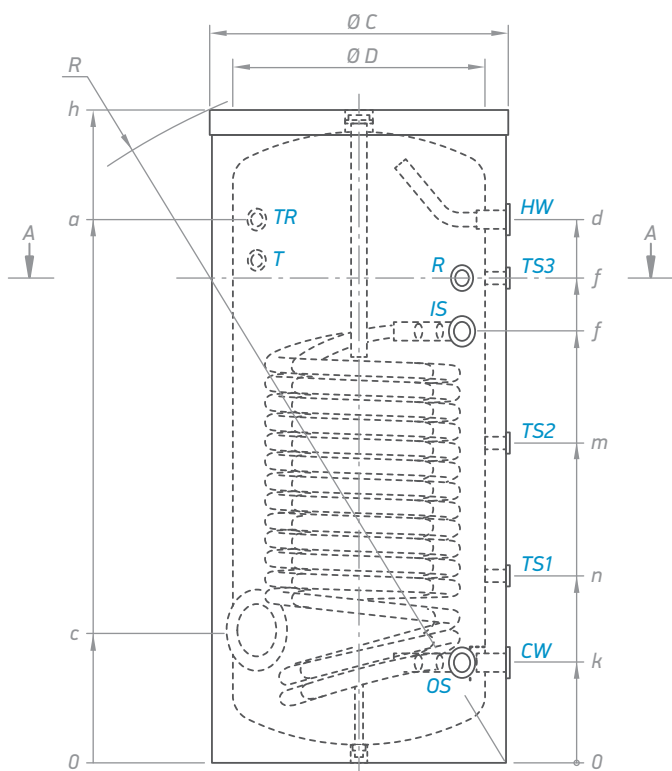

section A-A

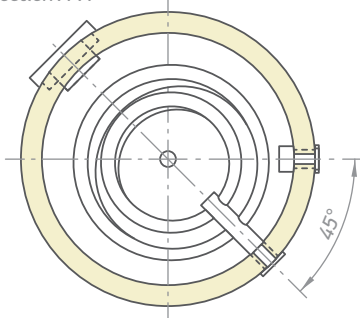

EV 2x12S 200 60
EV 2x15S 300 65
EV 2x23S 500 75

CW	- cold water inlet	G 1"
HW	- hot water outlet	G 1"
IS	- heat exchanger inlet	G 1"
OS	- heat exchanger outlet	G 1"
R	- recirculation	G ¾"
T	- thermometer	∅ 14 x 1.5
TR	- opening for thermoregulator	G ½"
TS1	- thermo pocket level 1	G ½"
TS2	- thermo pocket level 2	G ½"
TS3	- thermo pocket level 3	G ½"

Thread designations according to EN ISO 228-1!

MODEL		EV 2x4/2x9 S2 200 60	EV 2x5/2x12 S2 300 65	EV 2x6/2x13 S2 500 75	EV 2x9/2x17 S2 1000
Art. number	Nº	302168	302169	302170	303058
Capacity	L	195	283	483	969
Net weight	kg	85	116	172	314
Insulation (rigid PU)	mm	50	50	50	100
Heat exchanger surface S1/2	m ²	0.65 / 1.6	1.00 / 2.45	1.55 / 3.45	2.5 / 4.6
Heat exchanger capacity S1/2	L	4/9.5	6/14.7	9.3/21	14.4 / 27.5
Exchanged power in continuous mode (max coil output) S1(S2) *60-80 / 70-90°C	kW	16 / 22 (35 / 48)	24 / 32 (55 / 74)	38 / 51 (78 / 105)	
Continuous flow rate of DHW at ΔT 35°C (S1(S2)) *60-80 / 70-90°C	L/h	402 / 540 (870 / 1182)	594 / 798 (1344 / 1824)	936 / 1260 (1908 / 2592)	
Maximum quantity of drawn off water MIX 45°C (**15-60°C), Power input cut off (S1(S2))	L	282 / (175)	450 / (282)	750 / (474)	
Heat losses ΔT 45K	kWh/24h	1.4	1.7	2.3	3.4
Energy efficiency class		B	B	C	C
Maximum operational temperature	°C	95	95	95	95
Maximum operational temperature of heat exchanger	°C	110	110	110	110
Rated pressure	bar	8	8	8	8
Rated pressure of the heat exchanger	bar	6	6	6	6
Thermo pockets	pieces	2	3	3	3

* - outlet - inlet temperature of the heat transfer fluid

** - 15°C - cold water temperature, 60°C - hot water temperature (domestic water)

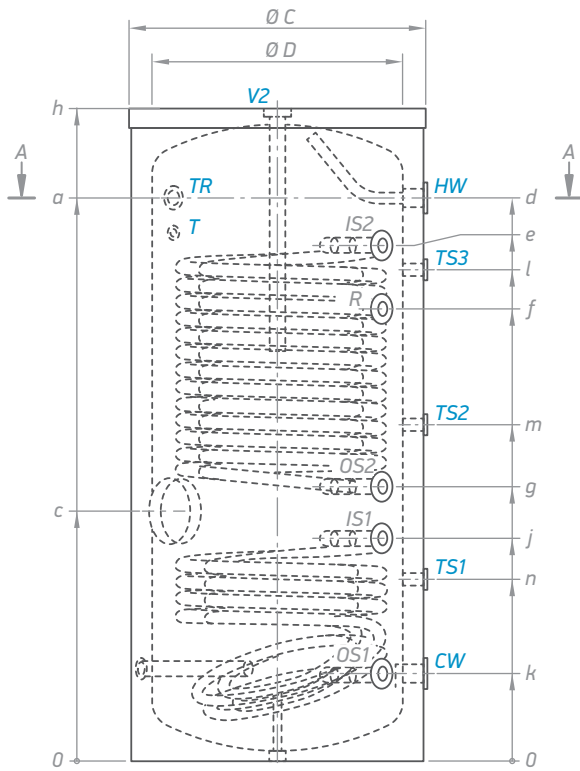

section A-A

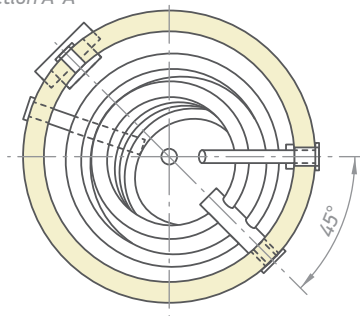

Dimensions ±5 mm					
h	mm	1202	1420	1670	2012
a	mm	996	1184	1447	1625
c	mm	483	533	642	734
d	mm	996	1184	1447	1846
e	mm	966	1150	1325	1625
f	mm	817	1055	1162	1374
g	mm	519	574	706	834
i	mm	434	485	572	637
j	mm	202	205	225	337
k	mm	202	205	225	81
l	mm	817	1055	1262	1374
m	mm	-	726	864	919
n	mm	360	398	467	470
R	mm	1345	1560	1823	2100
Ø C	mm	600	650	750	850
Ø D	mm	500	550	650	1010

EV 2x4/2x9 S2 200 60
EV 2x5/2x12 S2 300 65
EV 2x6/2x13 S2 500 75

EV 2x9/2x17 S2 1000

CW	- cold water inlet	G 1"	G 1½" B
HW	- hot water outlet	G 1"	G 1½" B
IS1	- heat exchanger inlet	G 1"	G 1½" B
IS2	- heat exchanger inlet	G 1"	G 1½" B
OS1	- heat exchanger outlet	G 1"	G 1½" B
OS2	- heat exchanger outlet	G 1"	G 1½" B
R	- recirculation	G ¾"	G ¾"
T	- thermometer	Ø 14 x 1.5	Ø 14 x 1.5
TR	- opening for thermoregulator	G ½"	G ½"
TS1	- thermo pocket level 1	G ½"	G ½"
TS2	- thermo pocket level 2	G ½"	G ½"
TS3	- thermo pocket level 3	G ½"	G ½"

Thread designations according to EN ISO 228-1!

Combined and indirectly heated storage tanks

Floor standing storage tanks for use with Gas boiler



MODEL		EV 8S 120 55 Z	EV 8S 160 60 Z
Art.number	Nº	303943	302421
Capacity	L	120	157
Net weight	kg	55	61
Insulation (rigid PU)	mm	50	50
Heat exchanger surface S1	m ²	0.75	0.75
Heat exchanger capacity S1	L	4.5	4.5
Exchanged power in continuous mode (max coil output) S1 *60-80°C	kW	13.5	13.5
Continuous flow rate of DHW at ΔT35°C (S1)*60-80/70-90°C	L/h	343	343
Maximum quantity of drawn off water MIX 45°C (**15-60°C), Power input cut off (S1)	L	186	242
Heat losses ΔT45K	kWh/24h	1.0	1.35
Energy efficiency class		B	B
Maximum operational temperature	T°C	95	95
Rated pressure	bar	8	8
Rated pressure of the heat exchanger	bar	6	6
Thermo pockets	pieces	1	1

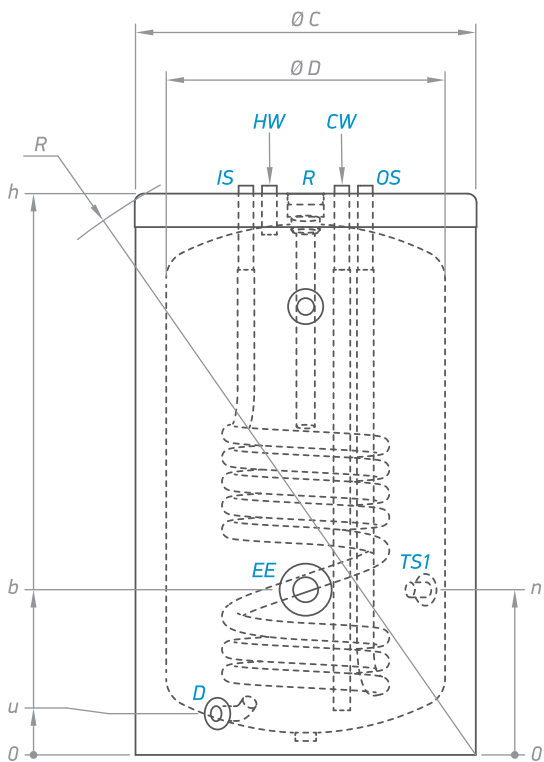

Dimensions ±5 mm		
h	mm	1002
a	mm	214
b	mm	296
c	mm	130
d	mm	145
e	mm	25
n	mm	368
u	mm	74
R	mm	1146
Ø C	mm	450
Ø D	mm	550

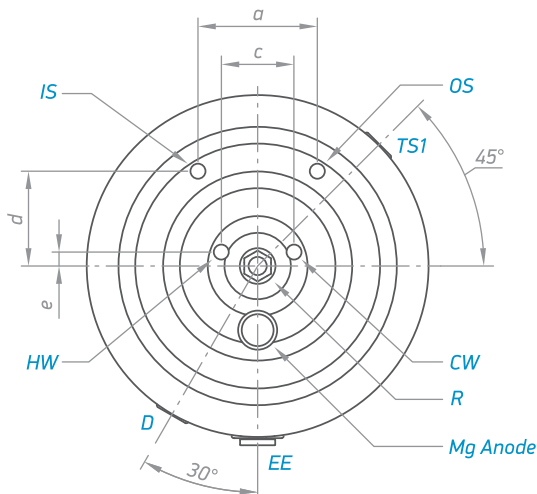

EV 8S 160 55 Z
EV 8S 160 60 Z

- TS1 - thermo pocket G ½"
- EE - electric heating element G 1½"
- T - thermometer -
- CW - inlet cold water G 1" B
- IS - inlet heat exchanger G ¾" B
- OS - outlet heat exchanger G ¾" B
- HW - outlet hot water G 1" B
- D - drainage G ¾" B
- R - recirculation G 1" B

Thread designations according to EN ISO 228-1!

Combined and indirectly heated storage tanks

Buffer tanks for domestic hot water



MODEL		EV 200 60	EV 300 65	EV 400 75	EV 500 75
Art. number	Nº	301399	301402	301405	301406
Capacity	L	200	300	400	500
Net weight	kg	45	66	117	110
Insulation (rigid PU)	mm	50	50	50	50
Heat losses ΔT 45K	kWh/24h	1.4	1.7	2.2	2.3
Energy efficiency class		B	B	C	C
Maximum operational temperature	°C	95	95	95	95
Rated pressure	bar	8	8	8	8
Thermo pockets	pieces	3	3	3	3

Dimensions ± 5 mm					
h	mm	1207	1427	1407	1702
a	mm	993	1207	1156	1445
b	mm	714	846	813	983
c	mm	314	314	331	321
d	mm	993	1207	1156	1445
f	mm	771	1010	943	1196
k	mm	199	203	220	211
R	mm	1345	1563	1596	1838
$\varnothing C$	mm	600	650	750	750
$\varnothing D$	mm	500	550	650	650

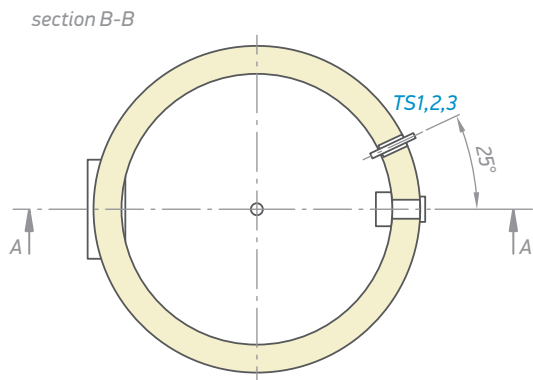
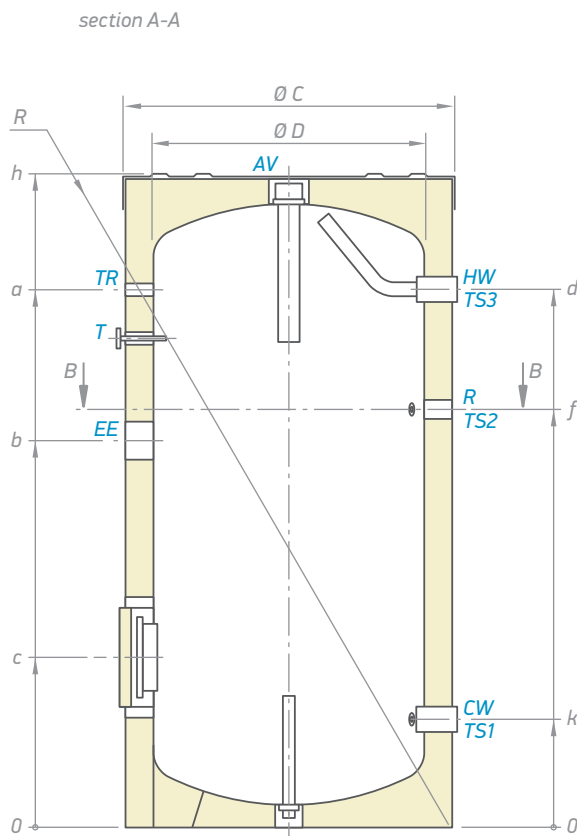

EV 200 60
EV 300 65
EV 400 75
EV 500 75

CW	- cold water inlet	G 1"
HW	- hot water outlet	G 1"
R	- recirculation	G ¾"
EE	- opening for electric element	G 1½"
T	- thermometer	Ø 14 x 1.5
TR	- opening for thermoregulator	G ½"
TS1	- thermo pocket level 1	G ½"
TS2	- thermo pocket level 2	G ½"
TS3	- thermo pocket level 3	G ½"

Thread designations according to EN ISO 228-1!

MODEL		EV 800 95 B - C	EV 1000 101 B - C
Art.number	Nº	303942	303941
Capacity	L	800	1000
Net weight	kg	175	211
Insulation	mm	80	80
Heat losses ΔT_{45K}	kWh/24h	3.1	3.4
Energy efficiency class		C	C
Maximum operational temperature	°C	95	95
Rated pressure	bar	8	8
Thermo pockets	pieces	3	3

Dimensions ± 5 mm			
h	mm	1947	2012
a	mm	1591	1656
b	mm	1050	1132
c	mm	350	354
d	mm	1577	1650
f	mm	1272	1274
k	mm	282	284
l	mm	1591	1656
m	mm	1172	1174
n	mm	268	272
R	mm	1927	2012
$\varnothing C$	mm	950	1010
$\varnothing D$	mm	790	850

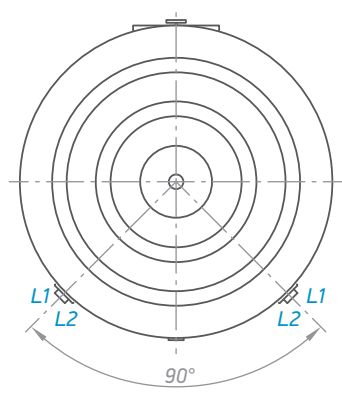
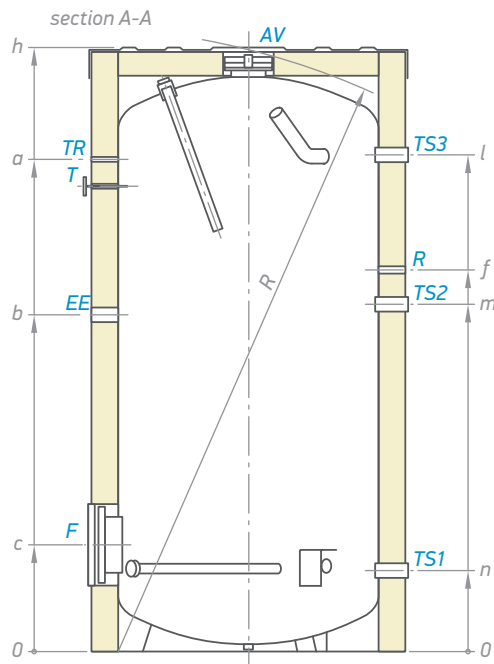
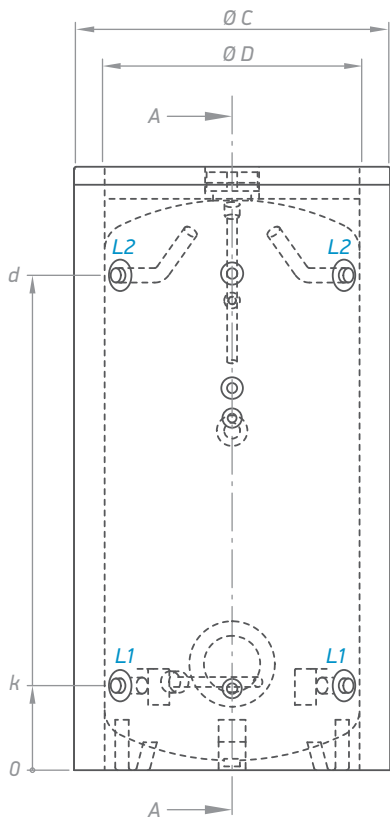

EV 800 95 B - C
EV 1000 101 B - C

AV	- air vent	G 3/4"
R	- recirculation	G 3/4"
TR	- opening for thermoregulator	G 1/2"
EE	- opening for electric element	G 1 1/2"
L1	- level 1	G 1 1/2" B
L2	- level 2	G 1 1/2" B
TS1	- thermo pocket level 1	G 1/2"
TS2	- thermo pocket level 2	G 1/2"
TS3	- thermo pocket level 3	G 1/2"

Thread designations according to EN ISO 228-1!

MODEL		EV 1500 120 B C	EV 2000 130 B C
Art. number	Nº	304331	304332
Capacity	L	1500	2000
Net weight	kg	338	388
Insulation	mm	100	100
Heat losses ΔT 45K	kWh/24h	3,8	4,4
Energy efficiency class		C	C
Maximum operational temperature	°C	95	95
Rated pressure	bar	8	8
Thermo pockets	pieces	2	2

Dimensions ± 5 mm			
h	mm	2212	2412
a	mm	1769	1917
b	mm	1170	1297
c	mm	470	487
d	mm	2070	2246
f	mm	1252	1360
k	mm	90	90
l	mm	1752	1905
m	mm	1082	1131
n	mm	370	387
R	mm	2361	2565
$\varnothing C$	mm	1200	1300
$\varnothing D$	mm	1000	1100

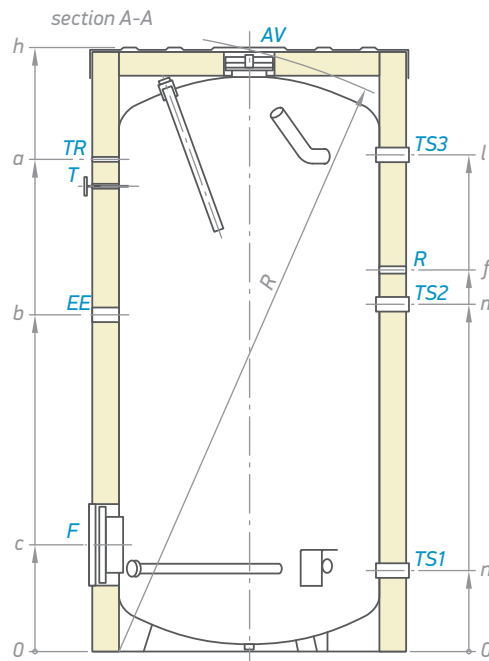
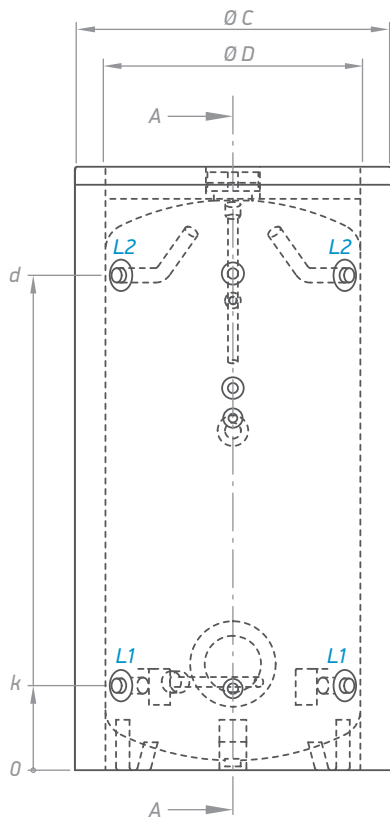

EV 1500 120 B C
EV 2000 130 B C

- AV - air vent G ¾"
- R - recirculation G 1½"
- TR - opening for thermoregulator G ½"
- EE - opening for electric element G 1½"
- L1,2 - level 1,2 G 2" B
- T - thermometer G Ø 14 x 1.5
- TS1, 2, 3 - thermo pocket level G ½"

Thread designations according to EN ISO 228-1!

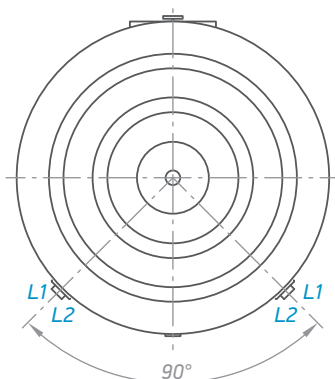

Combined and indirectly heated storage tanks

Mixing vessel



MODEL		V50 36
Art. number	Nº	422570
Capacity	L	49.2
Net weight	kg	24.2
Standing loss S	W	53
Energy efficiency class		C
Maximum operational temperature	°C	95
Maximum allowable pressure	bar	3

h	mm	1043
q	mm	225
r	mm	225
s	mm	225
t	mm	175
R	mm	1103
u	mm	190
v	mm	330
Ø C	mm	360
Ø D	mm	260

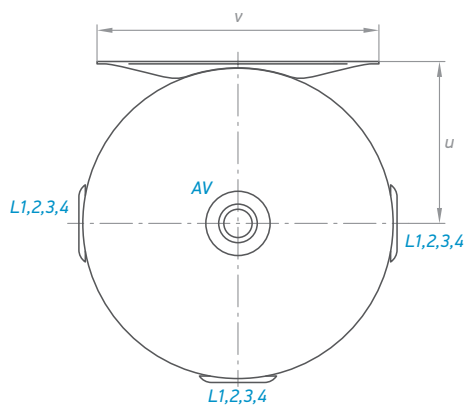
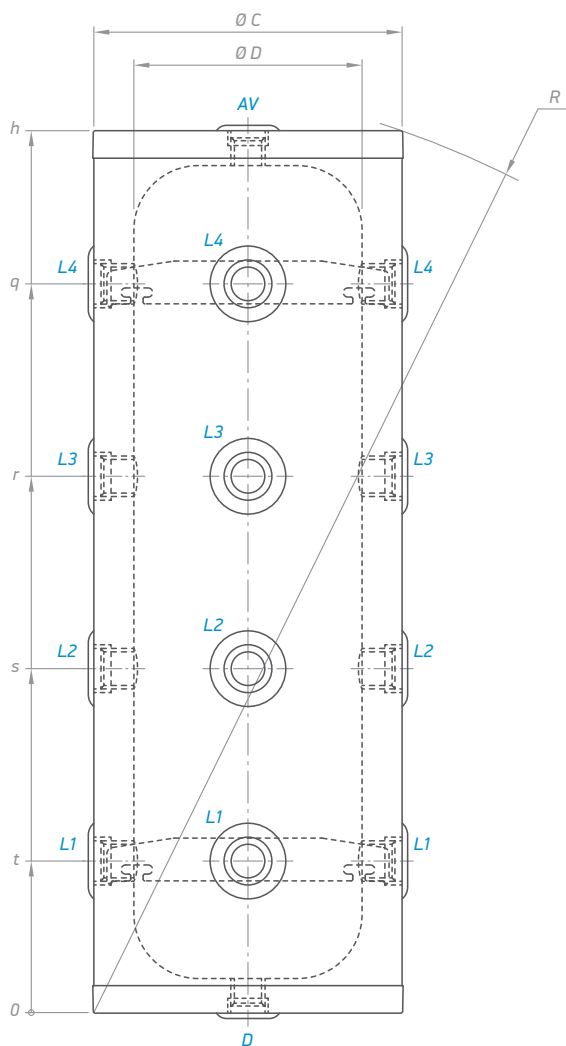

		V50 36
AV	- air vent	G 1"
D	- drainage	G 1"
TS1-3	- thermopockets	G ½"
L1-4	- levels	G 1½"

Indications des raccords conformes à la norme EN ISO 228-1!

Combined and indirectly heated storage tanks

Buffer tanks for active cooling systems



MODEL		VH 100 55 - AC
Art.number	Nº	303566
Capacity	L	101
Net weight	kg	34
Insulation (Rigid PU)	mm	73
Heat losses $\Delta T45K$	kWh/24h	0.83
Energy efficiency class		A
Maximum operational temperature	°C	95
Rated pressure	bar	3
Thermo pockets	pieces	1

Dimensions ±5 mm		
h	mm	932
q	mm	710
r	mm	550
s	mm	390
t	mm	230
u	mm	
R	mm	1081
Ø C	mm	550
Ø D	mm	404

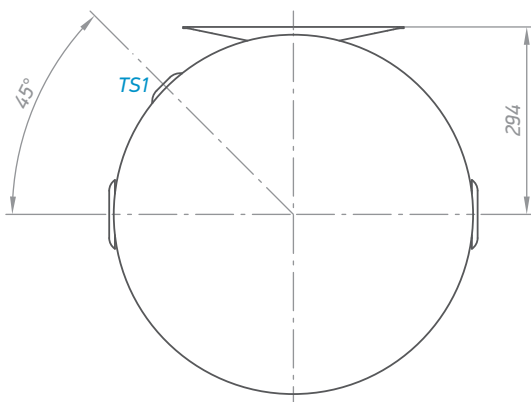
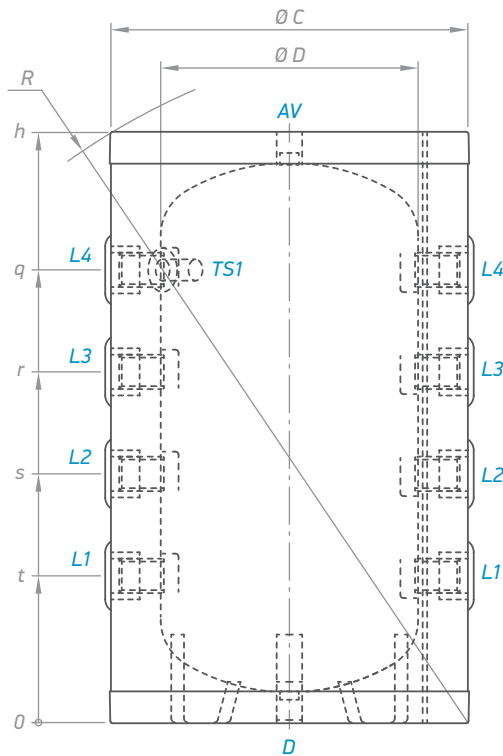

VH 100 55 - AC

- AV - air vent G 3/4"
- D - drainage G 3/4"
- L1 - levels 1 G 1 1/2"
- L2 - levels 2 G 1 1/2"
- L3 - levels 3 G 1 1/2"
- L4 - levels 4 G 1 1/2"
- TS1 - thermo pocket level 1 G 1/2"
- TS2 - thermo pocket level 2 G 1/2"
- TS3 - thermo pocket level 3 G 1/2"
- TS4 - thermo pocket level 4 G 1/2"

Thread designations according to EN ISO 228-1!

		V 160 60 - AC	V 200 60 - AC
Art.number	Nº	303564	303565
Capacity	L	160	202
Net weight	kg	40	44
Insulation (Rigid PU)	mm	50	50
Heat losses ΔT_{45K}	kWh/24h	1.2	1.35
Energy efficiency class		B	B
Maximum operational temperature	°C	95	95
Rated pressure	bar	3	3
Thermo pockets	pieces	2	2

Dimensions ± 5 mm			
h	mm	1007	1202
q	mm	779	995
r	mm	586	730
s	mm	393	465
t	mm	200	200
u	mm	75	75
R	mm	1169	1343
$\varnothing C$	mm	600	600
$\varnothing D$	mm	500	500

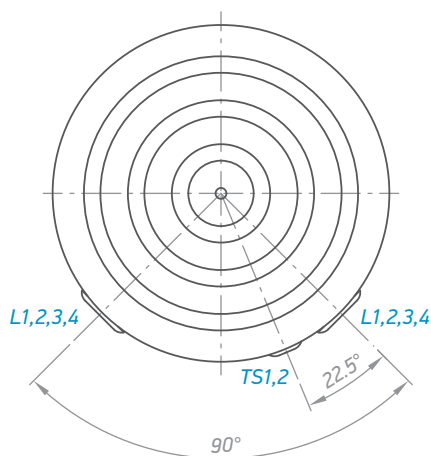
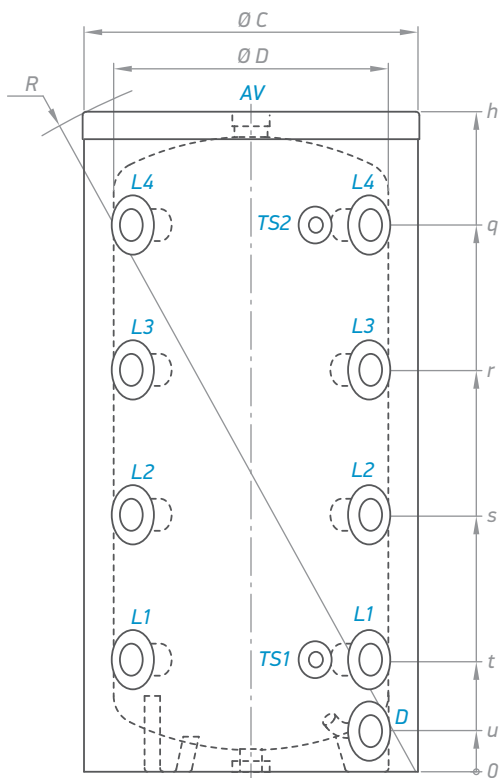

V 160 60 - AC
V 200 60 - AC

AV	- air vent	G 1½"
D	- drainage	G ¾" B
L1	- levels 1	G 1½"
L2	- levels 2	G 1½"
L3	- levels 3	G 1½"
L4	- levels 4	G 1½"
TS1	- thermo pocket level 1	G ½"
TS2	- thermo pocket level 2	G ½"
TS3	- thermo pocket level 3	G ½"
TS4	- thermo pocket level 4	G ½"

Thread designations according to EN ISO 228-1!

Combined and indirectly heated storage tanks

Buffer tanks for heating systems

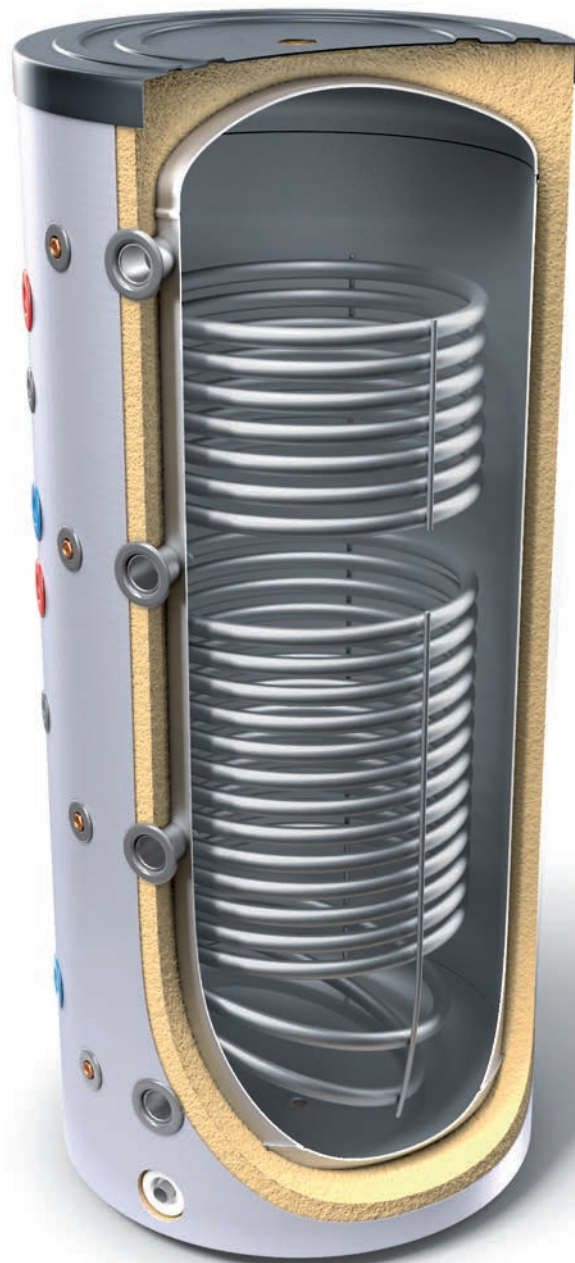

MODEL		V 200 60 F40 P4	V 300 65 F41 P4	V 400 75 F42 P4	V 500 75 F42 P4
Art. number	Nº	300632	300634	300635	300636
Capacity	L	200	300	400	500
Net weight	kg	40	59	113.5	121
Insulation (rigid PU)	mm	50	50	50	50
Heat losses ΔT 45K	kWh/24h	1.4	1.7	2.2	2.3
Energy efficiency class		B	B	C	C
Maximum operational temperature	°C	95	95	95	95
Rated pressure	bar	3	3	3	3
Number of inlets	pieces	4	4	4	4
Number of outlets	pieces	5	5	5	5
Thermo pockets	pieces	4	4	4	4

Dimensions ± 5 mm					
h	mm	1200	1420	1410	1674
q	mm	993	1208	1165	1451
r	mm	728	873	849	1039
s	mm	463	538	533	627
t	mm	198	203	217	215
u	mm	50	52	67	67
R	mm	1345	1563	1590	1823
$\emptyset D$	mm	500	550	650	650
$\emptyset C$	mm	600	650	750	750
ϕ	°	45	45	22.5	22.5

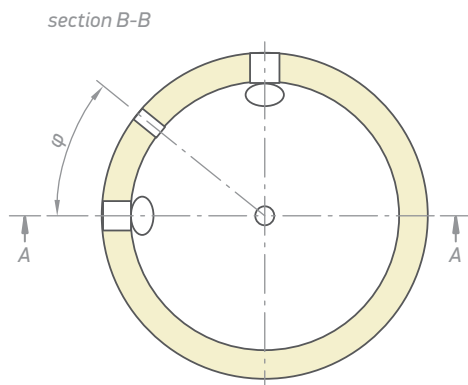
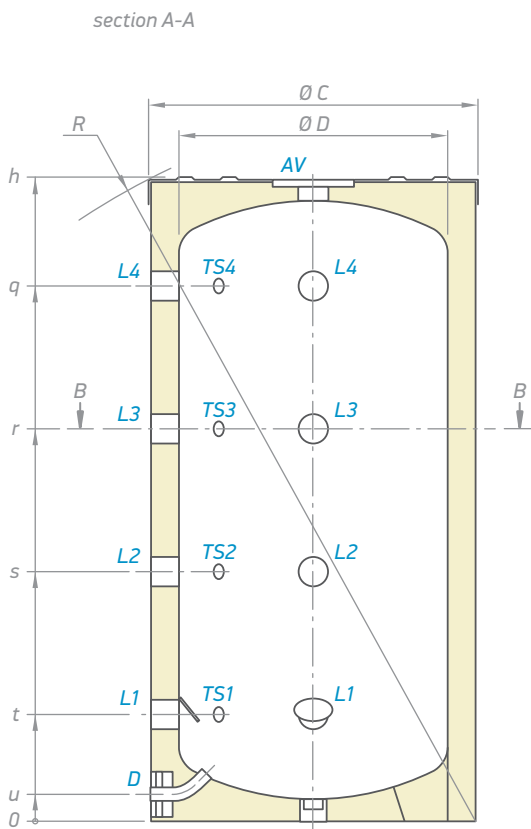

V 200 60 F40 P4
V 300 65 F41 P4
V 400 75 F42 P4
V 500 75 F42 P4

L1	- level 1	G 1½"
L2	- level 2	G 1½"
L3	- level 3	G 1½"
L4	- level 4	G 1½"
D	- drainage	G ¾"
AV	- air vent	G 1½"
TS1	- thermo pocket level 1	G ½"
TS2	- thermo pocket level 2	G ½"
TS3	- thermo pocket level 3	G ½"
TS4	- thermo pocket level 4	G ½"

Thread designations according to EN ISO 228-1!

MODEL		V 800 95 F43 P4 C	V 1000 95 C	V 1500 120 F45 P4 C	V 2000 130 F46 P4 C
Art. number	N°	303896	303897	303893	303894
Capacity	L	800	949	1500	2000
Net weight	kg	115	145	210	284
Insulation	mm	80	80	100	100
Heat losses ΔT 45K	kWh/24h	3.1	3.4	3.8	4.4
Energy efficiency class		C	C	C	C
Maximum operational temperature	°C	95	95	95	95
Rated pressure	bar	3	3	3	3
Thermo pockets	pieces	4	4	4	4
Number of inlets	pieces	4	4	4	4
Number of outlets	pieces	5	5	5	5

Dimensions ±5 mm					
h	mm	1947	2132	2220	2413
q	mm	1500	1774	1726	1896
r	mm	1120	1303	1293	1412
s	mm	740	832	860	929
t	mm	360	360	427	446
R	mm	1960	2155	2265	2481
Ø C	mm	950	950	1200	1300
Ø D	mm	790	790	1000	1100

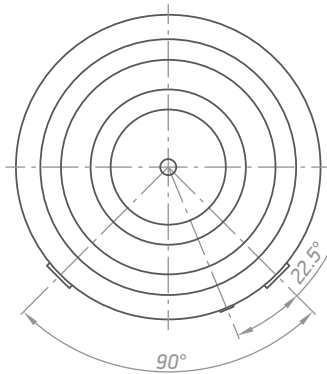
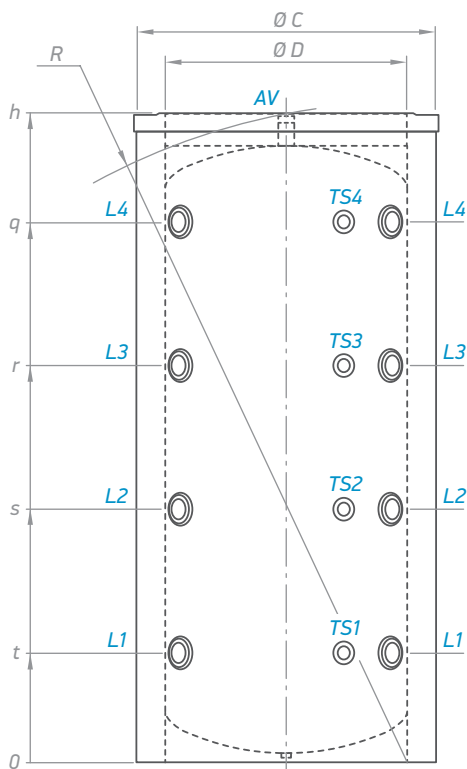

V 800 95 F43 P4 C
V 1000 95 C
V 1500 120 F45 P4 C
V 2000 130 F46 P4 C

L1	- level 1	G 1½"	G 2" B
L2	- level 2	G 1½"	G 2" B
L3	- level 3	G 1½"	G 2" B
L4	- level 4	G 1½"	G 2" B
AV	- air vent	G 1½"	G 2" B
TS1	- thermo pocket level 1	G ½"	G ½"
TS2	- thermo pocket level 2	G ½"	G ½"
TS3	- thermo pocket level 3	G ½"	G ½"
TS4	- thermo pocket level 4	G ½"	G ½"

Thread designations according to EN ISO 228-1!

MODEL		V 9S 200 60	V 12S 300 65	V 11S 400 75 F42 P5	V 15S 500 75 F42 P5
Art.number	Nº	302172	302173	300612	300624
Capacity	L	200	300	400	500
Net weight	kg	55	82	131	138
Heat Insulation (rigid PU)	mm	50	50	50	50
Heat exchanger surface S1	m ²	0.96	1.45	1.65	2.25
Heat exchanger capacity S1	L	5.8	8.8	10	13.7
Heat losses ΔT 45K	kWh/24h	1.4	1.7	2.8	3.1
Energy efficiency class		B	B	C	C
Maximum operational temperature	°C	95	95	95	95
Maximum operational temperature heat exchanger	°C	110	110	110	110
Rated pressure	bar	3	3	3	3
Rated pressure of the heat exchanger	bar	6	6	6	6
Thermo pockets	pieces	4	4	5	5
Number of inlets	pieces	4	4	4	4
Number of outlets	pieces	5	5	5	5

Dimensions ±5 mm					
h	mm	1202	1422	1409	1674
n				464	719
q	mm	995	1208	1165	1450
r	mm	730	873	849	1038
s	mm	465	538	533	626
t	mm	200	203	217	214
i	mm	655	817	780	719
j	mm	268	301	307	289
u	mm	75	75	75	75
R	mm	1343	1560	1590	1825
∅ C	mm	600	650	750	750
∅ D	mm	500	550	650	650

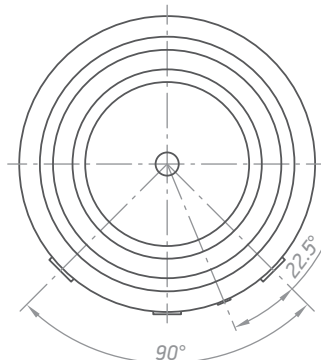
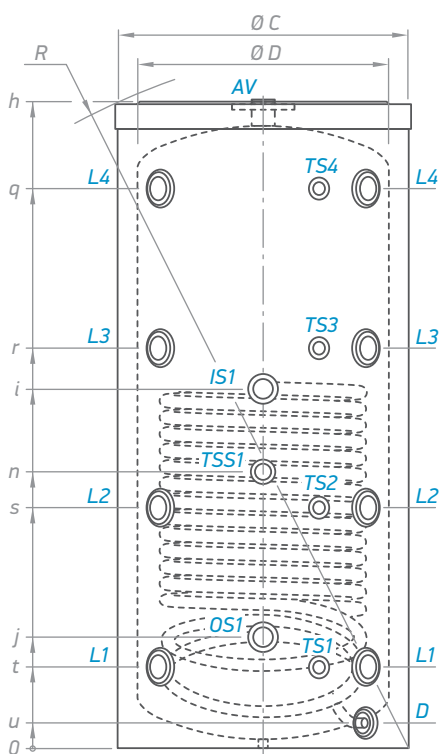

V 9S 200 60
V 12S 300 65

V 11S 400 75 F42 P5
V 15S 500 75 F42 P5

IS1	- heat exchanger inlet	G 1"	G 1"
OS1	- heat exchanger outlet	G 1"	G 1"
D	- drainage	G ¾" B	G ¾" B
AV	- air vent	G 1½"	G 1½"
L1	- level 1	G 1½"	G 1½"
L2	- level 2	G 1½"	G 1½"
L3	- level 3	G 1½"	G 1½"
L4	- level 4	G 1½"	G 1½"
TS1	- thermo pocket level 1	G ½"	G ½"
TS2	- thermo pocket level 2	G ½"	G ½"
TS3	- thermo pocket level 3	G ½"	G ½"
TS4	- thermo pocket level 4	G ½"	G ½"
TSS1	- thermo pocket heat exchanger	G ½"	G ½"

Thread designations according to EN ISO 228-1!

MODEL		V 12 S 800 95 F43 P5 C	V 15 S 1000 95 C	V 12 S 1500 120 F45 P5 C	V 15 S 2000 130 F46 P5 C
Art. number	Nº	303889	303899	303887	303892
Capacity	L	800	988	1500	1950
Net weight	kg	169	198	265	360
Insulation	mm	80	80	100	100
Heat exchanger surface S1	m ²	2.89	3.45	3.47	4.5
Heat exchanger capacity S1	L	26.2	31.3	31.4	41.6
Heat losses ΔT 45K	kWh/24h	3.1	3.4	3.8	4.4
Energy efficiency class		C	C	C	C
Rated pressure	bar	3	3	3	3
Rated pressure of the heat exchanger	bar	6	6	6	6
Maximum operational temperature	°C	95	95	95	95
Maximum operational temperature heat exchanger	°C	110	110	110	110
Thermo pockets	pieces	5	5	5	5
Number of inlets	pieces	4	4	4	4
Number of outlets	pieces	5	5	5	5

Dimensions ±5 mm					
h	mm	1947	2132	2220	2413
n	mm	581	581	647	646
q	mm	1500	1774	1726	1896
r	mm	1120	1303	1293	1412
s	mm	740	832	860	929
t	mm	360	360	427	446
i	mm	1021	1186	1087	1271
R	mm	1960	2155	2265	2481
Ø C	mm	950	950	1200	1300
Ø D	mm	790	790	1000	1100

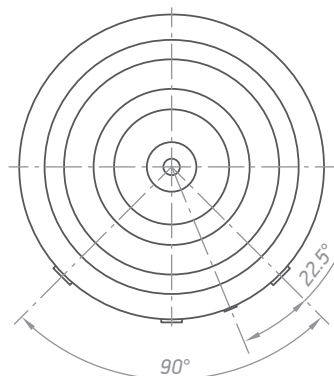
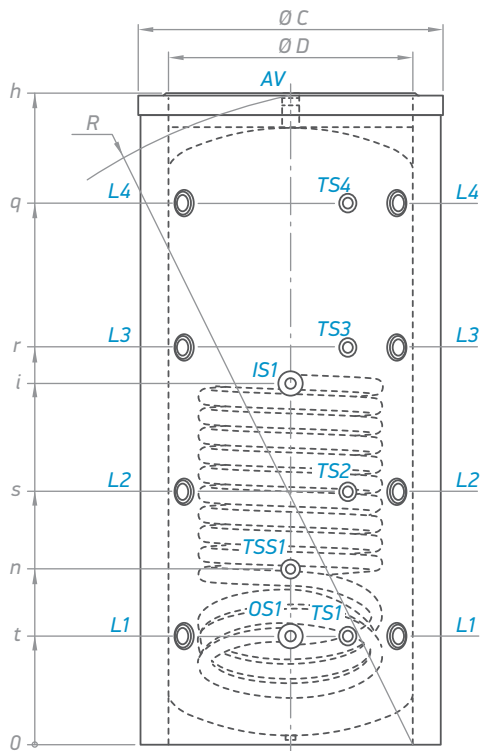

V 12 S 800 95 F43 P5 C
V 15 S 1000 95 C

V 12 S 1500 120 F45 P5 C
V 15 S 2000 130 F46 P5 C

IS1	- heat exchanger inlet	G 1½" B	G 1½" B
OS1	- heat exchanger outlet	G 1½" B	G 1½" B
AV	- air vent	G 1½"	G 2" B
L1	- level 1	G 1½"	G 2" B
L2	- level 2	G 1½"	G 2" B
L3	- level 3	G 1½"	G 2" B
L4	- level 4	G 1½"	G 2" B
TS1	- thermo pocket level 1	G ½"	G ½"
TS2	- thermo pocket level 2	G ½"	G ½"
TS3	- thermo pocket level 3	G ½"	G ½"
TS4	- thermo pocket level 4	G ½"	G ½"
TSS1	- thermo pocket heat exchanger	G ½"	G ½"

Thread designations according to EN ISO 228-1/

MODEL		V 11/5 S2 400 75 F42 P6	V15/7 S2 500 75 F42 P6
Art. number	Nº	300613	300625
Capacity	L	400	500
Net weight	kg	140	149.5
Insulation (rigid PU)	mm	50	50
Heat exchanger surface S1	m ²	1.65	2.25
Heat exchanger surface S2	m ²	0.76	1.04
Heat exchanger capacity S1	L	10	13.7
Heat exchanger capacity S2	L	4.6	6.4
Heat losses ΔT 45K	kWh/24h	2.8	3.1
Energy efficiency class		C	C
Rated pressure	bar	3	3
Rated pressure of the heat exchanger	bar	6	6
Maximum operational temperature	°C	95	95
Maximum operational temperature heat exchanger	°C	110	110
Thermo pockets	pieces	6	6
Number of inlets	pieces	4	4
Number of outlets	pieces	5	5

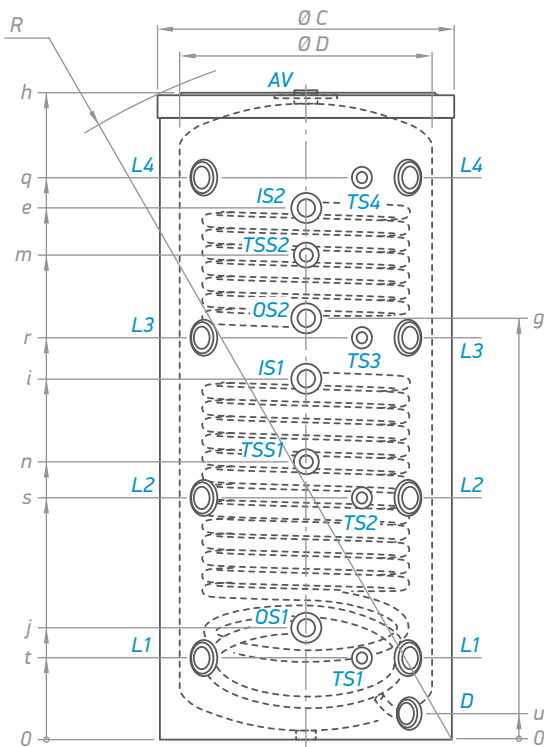

Dimensions ±5 mm			
h	mm	1411	1674
e	mm	1079	1349
g	mm	864	1048
i	mm	781	934
j	mm	308	289
m	mm	1002	1220
n	mm	465	719
q	mm	1166	1450
r	mm	850	1038
s	mm	534	626
t	mm	218	214
u	mm	68	67
R	mm	1592	1826
Ø D	mm	650	650
Ø C	mm	750	750

V 11/5S2 400 75 F42 P6
V15/7S2 500 75 F42 P6

IS1	- heat exchanger inlet	G 1"
IS2	- heat exchanger inlet	G 1"
OS1	- heat exchanger outlet	G 1"
OS2	- heat exchanger outlet	G 1"
D	- drainage	G ¾"
AV	- air vent	G 1½"
L1	- level 1	G 1½"
L2	- level 2	G 1½"
L3	- level 3	G 1½"
L4	- level 4	G 1½"
TS1	- thermo pocket level 1	G ½"
TS2	- thermo pocket level 2	G ½"
TS3	- thermo pocket level 3	G ½"
TS4	- thermo pocket level 4	G ½"
TSS1	- thermo pocket heat exchanger	G ½"
TSS2	- thermo pocket heat exchanger	G ½"

Thread designations according to EN ISO 228-1!

MODEL		V 12/9 S2 800 95 F43 P6 C	V 15/9 S2 1000 95 C	V 12/8 S2 1500 120 F45 P6 C	V 15/9 S2 2000 130 F46 P6 C
Art. number	Nº	303891	303900	303890	303870
Capacity	L	800	977	1500	1928
Net weight	kg	191	206	308	405
Insulation	mm	80	80	100	100
Heat exchanger surface S1	m ²	2.89	3.45	3.47	4.5
Heat exchanger surface S2	m ²	1.54	1.31	2.3	2.7
Heat exchanger capacity S1	L	26.2	31.3	31.4	41.6
Heat exchanger capacity S2	L	9.4	7.9	20.5	25.2
Heat losses ΔT 45K	kWh/24h	3.1	3.4	3.8	4.4
Energy efficiency class		C	C	C	C
Rated pressure	bar	3	3	3	3
Rated pressure of the heat exchanger	bar	6	6	6	6
Maximum operational temperature	°C	95	95	95	95
Maximum operational temperature heat exchanger	°C	110	110	110	110
Thermo pockets	pieces	6	6	6	6
Number of inlets	pieces	4	4	4	4
Number of outlets	pieces	5	5	5	5

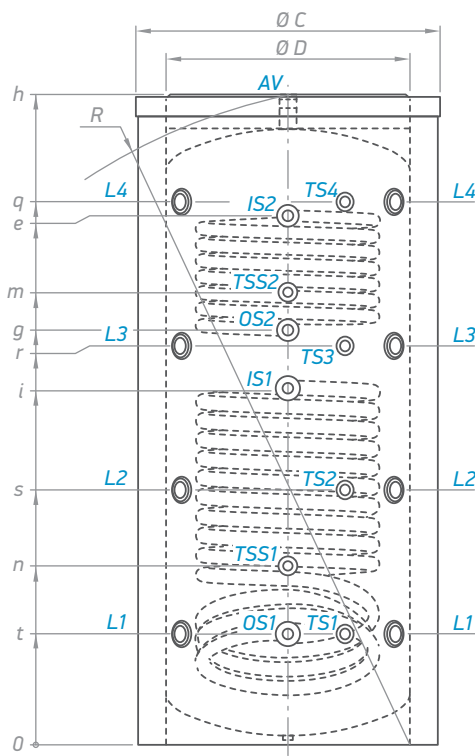

Dimensions ±5 mm					
h	mm	1947	2132	2220	2413
e	mm	1500	1774	1726	1896
g	mm	1120	1303	1293	1412
i	mm	1021	1186	1087	1271
m	mm	1388	1501	1461	1565
n	mm	581	581	647	646
q	mm	1508	1746	1733	1903
r	mm	1120	1360	1293	1412
s	mm	740	832	860	929
t	mm	360	360	427	446
R	mm	1960	2155	2265	2481
Ø C	mm	950	950	1200	1300
Ø D	mm	790	790	1000	1100

V 12/9 S2 800 95 F43 P6 C
V 15/9 S2 1000 95 C

V 12/8 S2 1500 120 F45 P6 C
V 15/9 S2 2000 130 F46 P6 C

IS1	- heat exchanger inlet	G 1½" B	G 1½" B
IS2	- heat exchanger inlet	G 1½" B	G 1½" B
OS1	- heat exchanger outlet	G 1½" B	G 1½" B
OS2	- heat exchanger outlet	G 1½" B	G 1½" B
AV	- air vent	G 1½"	G 2" B
L1	- level 1	G 1½"	G 2" B
L2	- level 2	G 1½"	G 2" B
L3	- level 3	G 1½"	G 2" B
L4	- level 4	G 1½"	G 2" B
TS1	- thermo pocket level 1	G ½"	G ½"
TS2	- thermo pocket level 2	G ½"	G ½"
TS3	- thermo pocket level 3	G ½"	G ½"
TS4	- thermo pocket level 4	G ½"	G ½"
TSS1	- thermo pocket heat exchanger	G ½"	G ½"
TSS2	- thermo pocket heat exchanger	G ½"	G ½"

Thread designations according to EN ISO 228-1!

Combined and indirectly heated storage tanks

Combined storage tanks for heating systems and domestic hot water production via hygienic coil

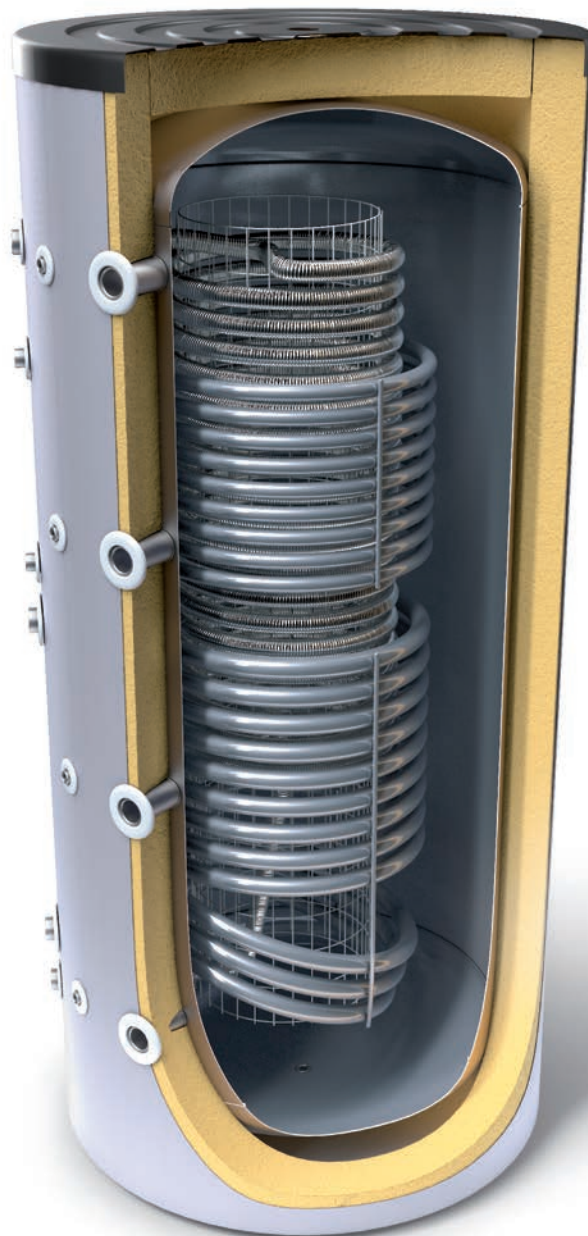

MODEL		V 500 75 HYG 5.0	V 800 95 HYG5.5 C	V 1000 95 HYG5.5 C
Art. number	Nº	303530	303844	303821
Nominal capacity buffer tank	L	489	770	919
Net weight	kg	130	143	163
Insulation	mm	50	80	80
Surface hygienic heat exchanger	m ²	5	5.5	5.5
Nominal volume hygienic heat exchanger	L	26	28	28
Heat loss ΔT 45K	kWh/24h	2.3	3.1	3.4
Energy efficiency class		C	C	C
Maximum operational temperature buffer tank	°C	95	95	95
Maximum operational temperature hygienic heat exchanger	°C	95	95	95
Rated pressure of buffer tank	bar	3	3	3
Rated pressure hygienic heat exchanger	bar	10	10	10
Thermo pockets	pieces	4	4	4
Number of inlets	pieces	4	4	4
Number of outlets	pieces	4	4	4

Dimensions ±5 mm				
b	mm	820	1051	1090
h	mm	1677	1932	2132
q	mm	1450	1500	1775
r	mm	1360	1120	1304
s	mm	624	740	833
t	mm	212	360	362
k	mm	212	290	290
R	mm	1825	1967	2167
∅C	mm	750	950	950
∅D	mm	650	790	790

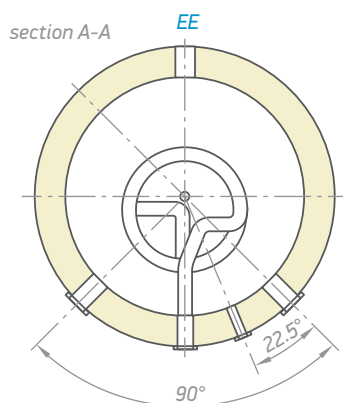
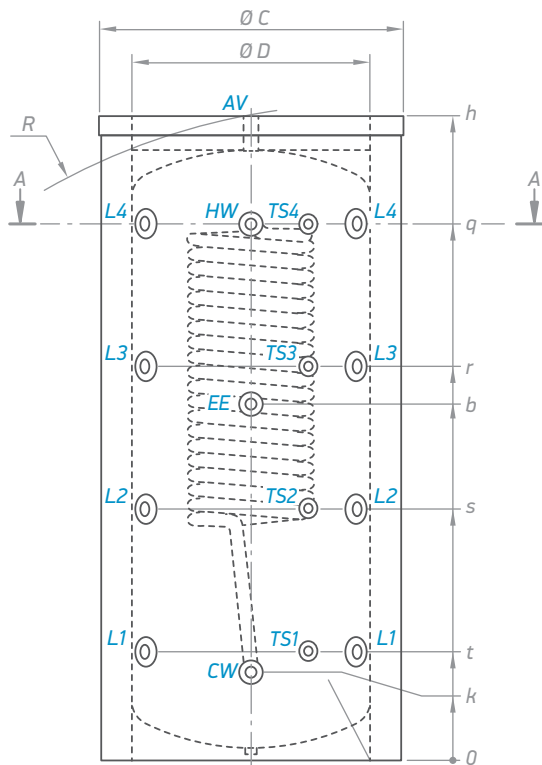

V 500 75 HYG 5.0
 V 800 95 HYG5.5 C
 V 1000 95 HYG5.5 C

CW	- cold water inlet	G 1" B	G 1¼" B
HW	- hot water outlet	G 1" B	G 1¼" B
AV	- air vent	G 1½"	G ¾"
L1	- levels 1	G 1½"	G 1½"
L2	- levels 2	G 1½"	G 1½"
L3	- levels 3	G 1½"	G 1½"
L4	- levels 4	G 1½"	G 1½"
TS1	- thermo pocket level 1	G ½"	G ½"
TS2	- thermo pocket level 2	G ½"	G ½"
TS3	- thermo pocket level 3	G ½"	G ½"
TS4	- thermo pocket level 4	G ½"	G ½"
EE	- electric heating element	G 1½"	G 1½"

Thread designations according to EN ISO 228-1!

MODEL		V 11S 500 75 HYG 5.0	V 10 S 800 95 HYG5.5 HE C	V 10 S 1000 95 HYG5.5 HE C
Art. number	Nº	303534	303825	303822
Nominal capacity buffer tank	L	480	742	891
Net weight	kg	150	188	214
Insulation	mm	50	80	80
Heat exchanger surface S1	m ²	1.65	2.23	2.23
Surface hygienic heat exchanger	m ²	5	5.5	5.5
Heat exchanger content S1	L	10	19.2	19.2
Nominal volume hygienic heat exchanger	L	26	28	28
Heat loss ΔT 45K	kWh/24h	2.3	3.1	3.4
Energy efficiency class		C	C	C
Maximum operational temperature buffer tank	°C	95	95	95
Maximum operational temperature hygienic heat exchanger	°C	95	95	95
Maximum working temperature coil heat exchanger	°C	110	110	110
Rated pressure of buffer tank	bar	3	3	3
Rated pressure hygienic heat exchanger	bar	10	10	10
Rated pressure of coil heat exchanger	bar	6	6	6
Thermo pockets	pieces	4	4	4
Number of inlets	pieces	4	4	4
Number of outlets	pieces	4	4	4

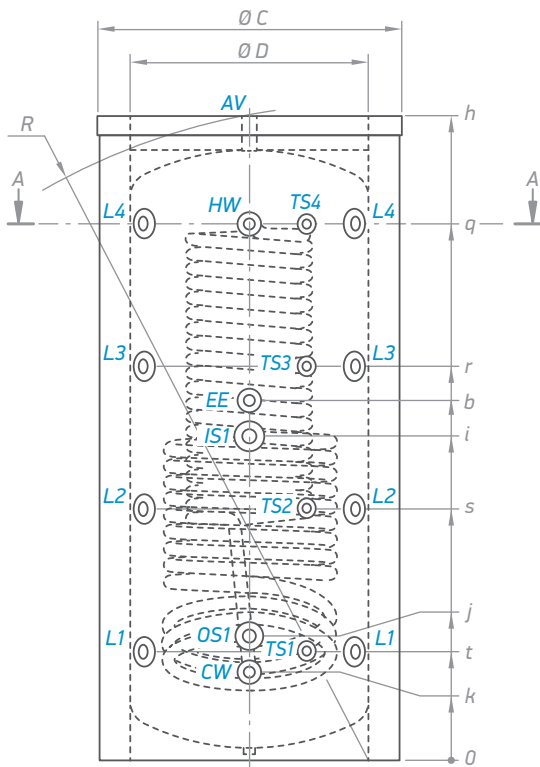

Dimensions ±5 mm				
b	mm	820	1051	1090
h	mm	1677	1932	2132
q	mm	1450	1500	1775
r	mm	1360	1120	1304
i	mm	780	964	966
s	mm	624	740	833
j	mm	307	409	412
t	mm	212	360	362
k	mm	212	290	290
R	mm	1825	1967	2167
ØC	mm	750	950	950
ØD	mm	650	790	790

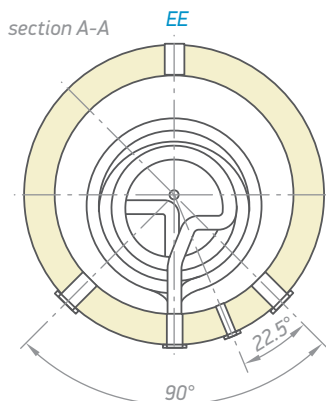

V 11S 500 75 HYG 5.0

V 10 S 800 95 HYG5.5 HE C
V 10 S 1000 95 HYG5.5 HE C

CW	- cold water inlet	G 1" B	G 1¼" B
HW	- hot water outlet	G 1" B	G 1¼" B
IS1	- heat exchanger inlet	G 1" B	G 1½" B
OS1	- heat exchanger outlet	G 1" B	G 1½" B
AV	- air vent	G 1½"	G 1½"
L1	- levels 1	G 1½"	G 1½"
L2	- levels 2	G 1½"	G 1½"
L3	- levels 3	G 1½"	G 1½"
L4	- levels 4	G 1½"	G 1½"
TS1	- thermo pocket level 1	G ½"	G ½"
TS2	- thermo pocket level 2	G ½"	G ½"
TS3	- thermo pocket level 3	G ½"	G ½"
TS4	- thermo pocket level 4	G ½"	G ½"
EE	- electric heating element	G 1½"	G 1½"

Thread designations according to EN ISO 228-1!

MODEL		V 10/6 S2 800 95 HYG 5.5 HE C	V 10/9 S2 1000 95 HYG5.5 HE C
Art. number	Nº	303829	303830
Nominal capacity buffer tank	L	735	881
Net weight	kg	210	230
Insulation	mm	80	80
Heat exchanger surface S1	m ²	2.23	2.23
Heat exchanger surface S2	m ²	1	1.54
Surface hygienic heat exchanger	m ²	5.5	5.5
Heat exchanger content S1	L	19.2	19.2
Heat exchanger content S2	L	5.9	8.7
Nominal volume hygienic heat exchanger	L	28	28
Heat loss ΔT 45K	kWh/24h	3.1	3.4
Energy efficiency class		C	C
Maximum operational temperature buffer tank	°C	95	95
Maximum operational temperature hygienic heat exchanger	°C	95	95
Maximum working temperature coil heat exchanger	°C	110	110
Rated pressure of buffer tank	bar	3	3
Rated pressure hygienic heat exchanger	bar	10	10
Rated pressure of coil heat exchanger	bar	6	6

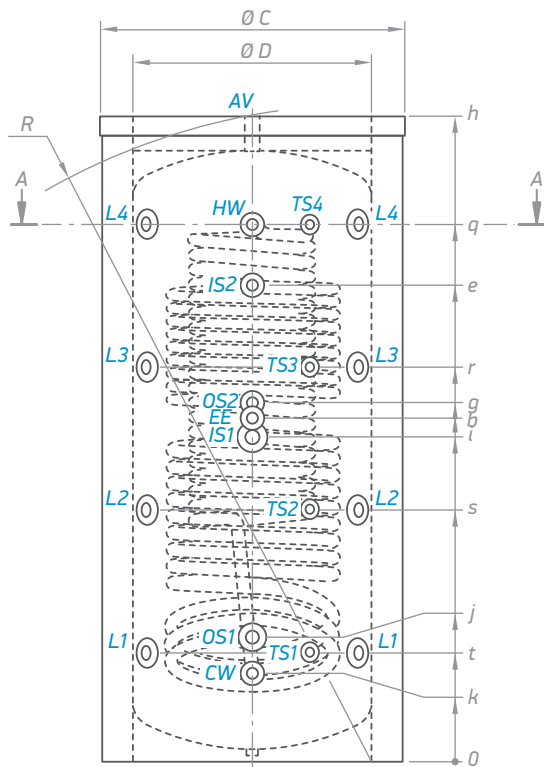

Dimensions ±5 mm			
b	mm	1051	1090
h	mm	1932	2132
q	mm	1500	1775
e	mm	1422	1574
r	mm	1120	1304
g	mm	1164	1187
i	mm	964	966
s	mm	740	833
j	mm	409	412
t	mm	360	362
k	mm	290	290
R	mm	1967	2167
ØC	mm	950	950
ØD	mm	790	790

V 10/6 S2 800 95 HYG 5.5 HE C
V 10/9 S2 1000 95 HYG5.5 HE C

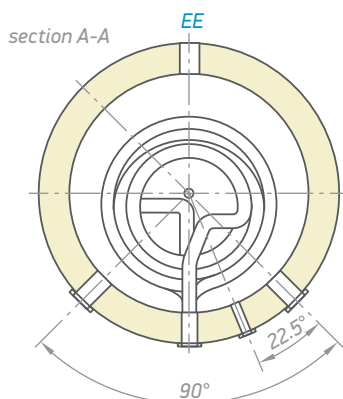

CW	- cold water inlet	G 1¼" B
HW	- hot water outlet	G 1¼" B
IS1	- heat exchanger inlet	G 1½" B
IS2	- heat exchanger inlet	G 1" B
OS1	- heat exchanger outlet	G 1½" B
OS2	- heat exchanger outlet	G 1" B
AV	- air vent	G 1½"
L1	- levels 1	G 1½"
L2	- levels 2	G 1½"
L3	- levels 3	G 1½"
L4	- levels 4	G 1½"
TS1	- thermo pocket level 1	G ½"
TS2	- thermo pocket level 2	G ½"
TS3	- thermo pocket level 3	G ½"
TS4	- thermo pocket level 4	G ½"
EE	- electric heating element	G 1½"

Thread designations according to EN ISO 228-1!

Combined and indirectly heated storage tanks

Combined storage tanks for heating systems and domestic hot water - tank in tank

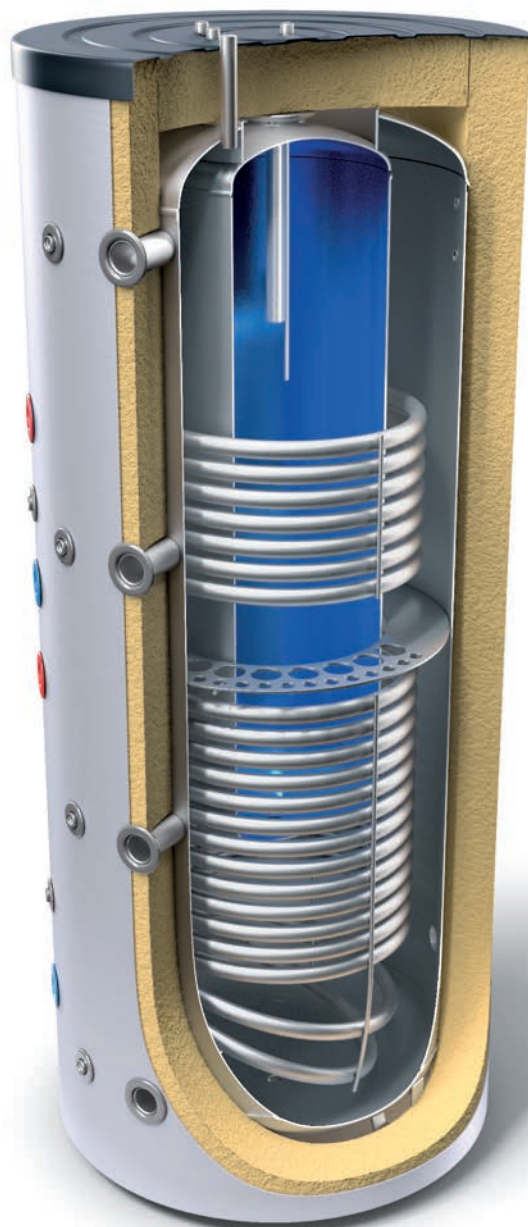

MODEL		V 600 81 EV 150 40 C	V 800 95 EV 200 45 C	V 1000 95 EV 200 45 C	V 1500 120 EV 300 55 C
Art. number	Nº	303871	303874	303875	303869
Actual capacity buffer tank	L	461	616	750	1184
Actual capacity hot water tank	L	142	184	184	302
Net weight	kg	161	193	220	295
Insulation	mm	80	80	80	100
Heat loss ΔT 45K	kWh/24h	2.8	3.1	3.4	3.8
Energy efficiency class		C	C	C	C
Maximum operational temperature buffer tank	°C	95	95	95	95
Maximum operational temperature hot water tank	°C	95	95	95	95
Rated pressure of buffer tank	bar	3	3	3	3
Rated pressure of hot water tank	bar	10	10	10	10
Thermo pockets	pieces	4	4	4	4
Number of inlets	pieces	4	4	4	4
Number of outlets	pieces	4	4	4	4

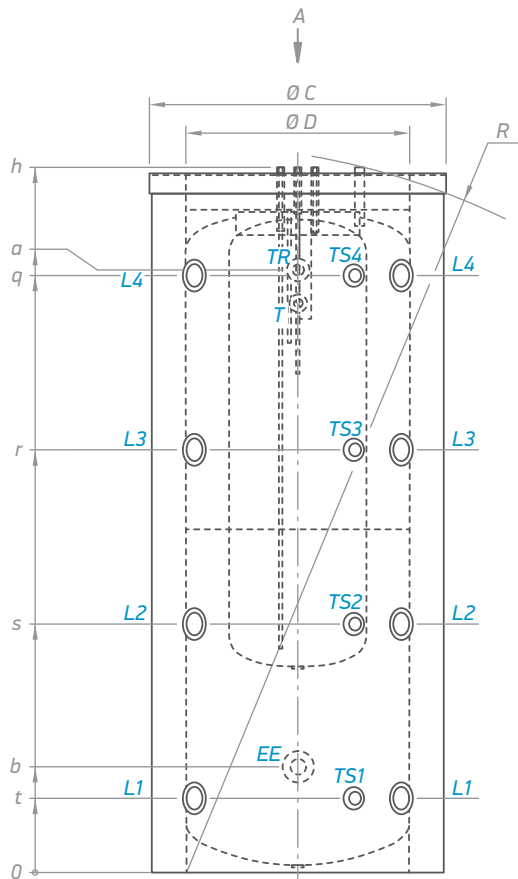

Dimensions ± 5 mm					
h	mm	2065	1956	2141	2216
a	mm	1747	1600	1795	1740
b	mm	307	400	400	470
o	mm	130	150	150	150
q	mm	1738	1502	1775	1726
r	mm	1230	1122	1304	1293
s	mm	722	742	833	860
t	mm	214	362	362	427
w	mm	22	22	22	22
x	mm	110	100	100	110
z	mm	100	100	100	100
R	mm	2121	2045	2236	2238
Ø C	mm	810	950	950	1200
Ø D	mm	650	790	790	1000

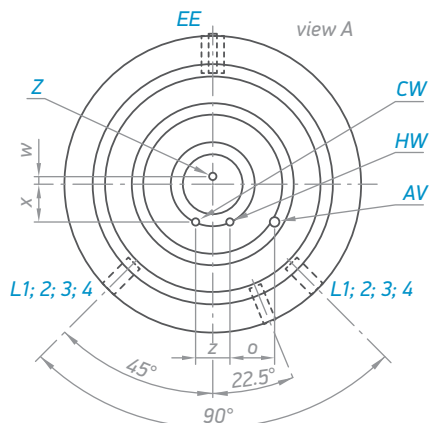

	V 600 81 EV 150 40 C	V 800 95 EV 200 45 C	V 1000 95 EV 200 45 C	V 1500 120 EV 300 55 C
--	-------------------------	-------------------------	--------------------------	---------------------------

CW	- inlet cold water	G 1/2" B	G 1" B	G 1" B	G 1" B
HW	- outlet hot water	G 1/2" B	G 1" B	G 1" B	G 1" B
AV	- air vent	G 1/2"	G 1/2"	G 1/2"	G 1/2"
Z	- recirculation	G 1/2" B	G 1/2" B	G 1/2" B	G 1/2" B
T	- thermometer	Ø 14 x 1.5	Ø 14 x 1.5	Ø 14 x 1.5	Ø 14 x 1.5
TR	- thermoregulator	G 1/2"	G 1/2"	G 1/2"	G 1/2"
EE	- electric heating element	G 1 1/2"	G 1 1/2"	G 1 1/2"	G 1 1/2"
L1	- levels 1	G 1 1/2"	G 1 1/2"	G 1 1/2"	G 2" B
L2	- levels 2	G 1 1/2"	G 1 1/2"	G 1 1/2"	G 2" B
L3	- levels 3	G 1 1/2"	G 1 1/2"	G 1 1/2"	G 2" B
L4	- levels 4	G 1 1/2"	G 1 1/2"	G 1 1/2"	G 2" B
TS1	- thermo pocket level 1	G 1/2"	G 1/2"	G 1/2"	G 1/2"
TS2	- thermo pocket level 2	G 1/2"	G 1/2"	G 1/2"	G 1/2"
TS3	- thermo pocket level 3	G 1/2"	G 1/2"	G 1/2"	G 1/2"
TS4	- thermo pocket level 4	G 1/2"	G 1/2"	G 1/2"	G 1/2"

Thread designations according to EN ISO 228-1!

MODEL		V 15/7 S2 600 81 EV 150 40 C	V 12 S 800 95 EV 200 45 C	V 15 S 1000 95 EV 200 45 C	V 12 S 1500 120 EV 300 55 C
Art. number	Nº	303868	303849	303876	303846
Actual capacity buffer tank	L	447	590	702	1153
Actual capacity hot water tank	L	142	184	184	302
Net weight	kg	188	241	274	353
Insulation	mm	80	80	80	100
Heat exchanger surface S1	m ²	2.25	2.89	3.3	3.47
Heat exchanger content S1	L	13.7	26.2	29	31.4
Heat loss ΔT 45K	kWh/24h	2.8	3.1	3.4	3.8
Energy efficiency class	C	C	C	C	C
Maximum operational temperature buffer tank	°C	95	95	95	95
Maximum operational temperature hot water tank	°C	95	95	95	95
Maximum working temperature coil heating element	°C	110	110	110	110
Rated pressure of buffer tank	bar	3	3	3	3
Rated pressure of hot water tank	bar	10	10	10	10
Rated pressure of coil heat exchanger	bar	6	6	6	6
Thermo pockets	pieces	5	5	5	5
Number of inlets	pieces	4	4	4	4
Number of outlets	pieces	4	4	4	4

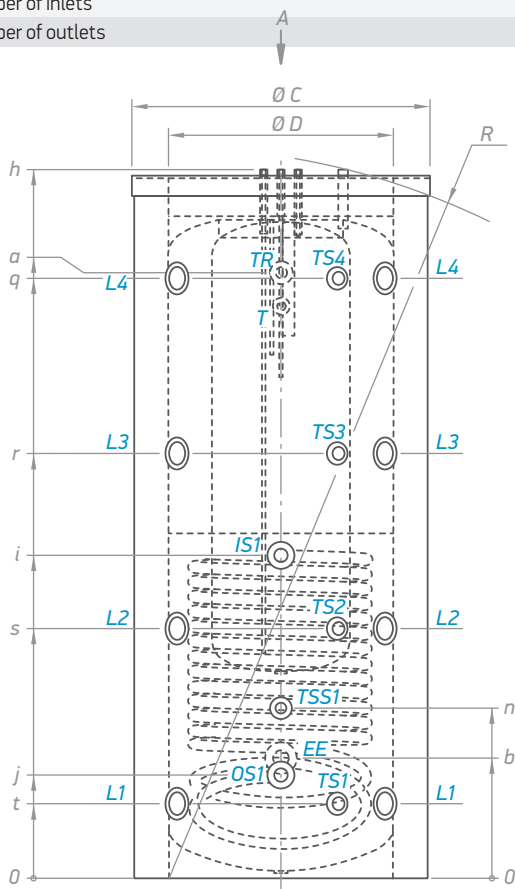

Dimensions ±5 mm					
h	mm	2065	1956	2141	2216
a	mm	1747	1600	1795	1740
b	mm	307	400	400	470
i	mm	934	1022	1187	1087
j	mm	289	362	362	427
n	mm	489	582	582	647
o	mm	130	150	150	150
q	mm	1738	1502	1775	1726
r	mm	1230	1122	1304	1293
s	mm	722	742	833	860
t	mm	214	362	362	427
w	mm	22	22	22	22
x	mm	110	100	100	110
z	mm	100	100	100	100
R	mm	2121	2045	2236	2238
Ø C	mm	810	950	950	1200
Ø D	mm	650	790	790	1000

	V 15/7 S2 600 81 EV 150 40 C	V 12 S 800 95 EV 200 45 C	V 15 S 1000 95 EV 200 45 C	V 12 S 1500 120 EV 300 55 C
CW	- inlet cold water	G ½" B	G 1" B	G 1" B
HW	- outlet hot water	G ½" B	G 1" B	G 1" B
IS1	- heat exchanger inlet	G 1"	G 1½" B	G 1½" B
OS1	- heat exchanger outlet	G 1"	G 1½" B	G 1½" B
AV	- air vent	G ½"	G ½"	G ½"
Z	- recirculation	G ½" B	G ½" B	G ½" B
T	- thermometer	Ø 14 x 1.5	Ø 14 x 1.5	Ø 14 x 1.5
TR	- thermoregulator	G ½"	G ½"	G ½"
EE	- electric heating element	G 1½"	G 1½"	G 1½"
L1	- levels 1	G 1½"	G 1½"	G 2" B
L2	- levels 2	G 1½"	G 1½"	G 2" B
L3	- levels 3	G 1½"	G 1½"	G 2" B
L4	- levels 4	G 1½"	G 1½"	G 2" B
TS1	- thermo pocket level 1	G ½"	G ½"	G ½"
TS2	- thermo pocket level 2	G ½"	G ½"	G ½"
TS3	- thermo pocket level 3	G ½"	G ½"	G ½"
TS4	- thermo pocket level 4	G ½"	G ½"	G ½"
TSS1	- thermo pocket level exchanger	G ½"	G ½"	G ½"

Thread designations according to EN ISO 228-1!

MODEL		V 15/7 S2 600 81 EV 150 40 C	V 12/9 S2 800 95 EV 200 45 C	V 15/9 S2 1000 95 EV 200 45 C	V 12/8 S2 1500 120 EV 300 55 C
Art. number	Nº	303868	303864	303877	303861
Actual capacity buffer tank	L	440	578	693	1128
Actual capacity hot water tank	L	142	184	184	302
Net weight	kg	203	264	298	390
Insulation	mm	80	80	80	100
Heat exchanger surface S1	m²	2.25	2.89	3.3	3.47
Heat exchanger surface S2	m²	1.04	1.54	1.54	2.3
Heat exchanger content S1	L	13.7	26.2	29	31.4
Heat exchanger content S2	L	6.4	9.4	9.4	20.5
Heat loss ΔT 45K	kWh/24h	2.8	3.1	3.4	3.8
Energy efficiency class	C	C	C	C	C
Maximum operational temperature buffer tank	°C	95	95	95	95
Maximum operational temperature hot water tank	°C	95	95	95	95
Maximum working temperature coil heating element	°C	110	110	110	110
Rated pressure of buffer tank	bar	3	3	3	3
Rated pressure of hot water tank	bar	10	10	10	10
Rated pressure of coil heat exchanger	bar	6	6	6	6
Thermo pockets	pieces	6	6	6	6
Number of inlets	pieces	4	4	4	4
Number of outlets	pieces	4	4	4	4

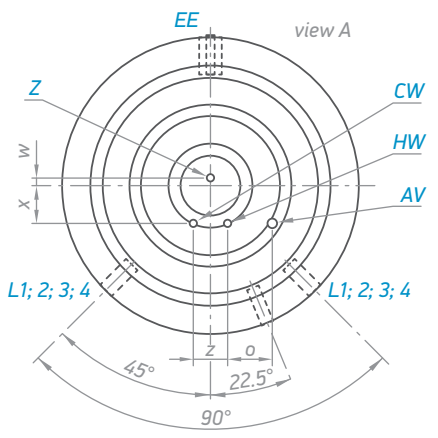
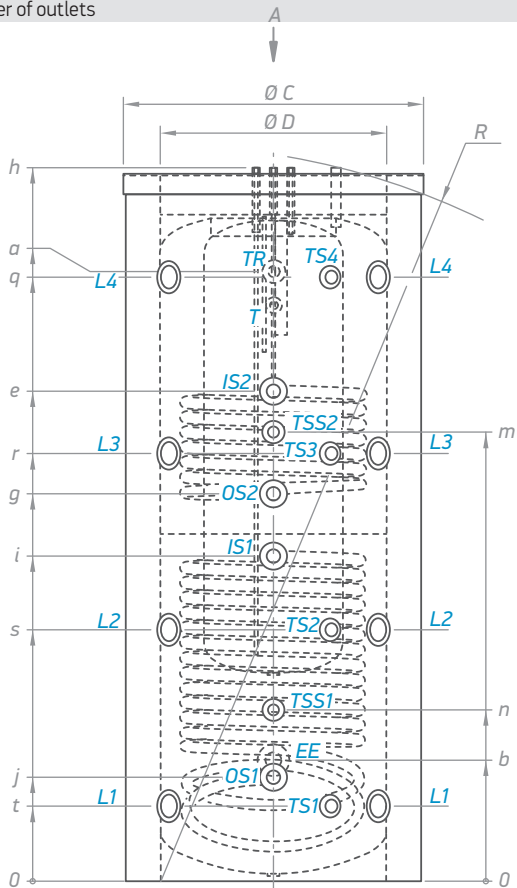

Dimensions ±5 mm					
h	mm	2065	1956	2141	2216
a	mm	1747	1600	1795	1740
b	mm	307	400	400	470
e	mm	1408	1509	1747	1733
g	mm	1107	1122	1360	1293
i	mm	934	1022	1187	1087
j	mm	289	362	362	427
m	mm	1257	1387	1502	1461
n	mm	489	582	582	647
o	mm	130	150	150	150
q	mm	1738	1502	1775	1726
r	mm	1230	1122	1304	1293
s	mm	722	742	833	860
t	mm	214	362	362	427
w	mm	22	22	22	22
x	mm	110	100	100	110
z	mm	100	100	100	100
R	mm	2121	2045	2236	2238
Ø C	mm	810	950	950	1200
Ø D	mm	650	790	790	1000

	V 15/7 S2 600 81 EV 150 40 C	V 12/9 S2 800 95 EV 200 45 C	V 15/9 S2 1000 95 EV 200 45 C	V 12/8 S2 1500 120 EV 300 55 C
CW	- inlet cold water	G ½" B	G 1" B	G 1" B
HW	- outlet hot water	G ½" B	G 1" B	G 1" B
IS1	- heat exchanger inlet	G 1"	G 1½" B	G 1½" B
IS2	- heat exchanger inlet	G 1"	G 1" B	G 1" B
OS1	- heat exchanger outlet	G 1"	G 1" B	G 1" B
OS2	- heat exchanger outlet	G 1"	G 1½" B	G 1½" B
AV	- air vent	G ½"	G ½"	G ½"
Z	- recirculation	G ½" B	G ½" B	G ½" B
T	- thermometer	Ø 14 x 1.5	Ø 14 x 1.5	Ø 14 x 1.5
TR	- thermoregulator	G ½"	G ½"	G ½"
EE	- electric heating element	G 1½"	G 1½"	G 1½"
L1	- levels 1	G 1½"	G 1½"	G 1½"
L2	- levels 2	G 1½"	G 1½"	G 1½"
L3	- levels 3	G 1½"	G 1½"	G 1½"
L4	- levels 4	G 1½"	G 1½"	G 1½"
TS1	- thermo pocket level 1	G ½"	G ½"	G ½"
TS2	- thermo pocket level 2	G ½"	G ½"	G ½"
TS3	- thermo pocket level 3	G ½"	G ½"	G ½"
TS4	- thermo pocket level 4	G ½"	G ½"	G ½"
TSS1	- thermo pocket heat exchanger	G ½"	G ½"	G ½"
TSS2	- thermo pocket heat exchanger	G ½"	G ½"	G ½"

Thread designations according to EN ISO 228-1!

Combined and indirectly heated storage tanks

Accessories



Volume	Power	Name	Art. N°	Description
Electric sets:				
from 160 up to 500L	3 kW	Water heater set 3 kW plug and play (from 160 up to 500 L)	301456	Package includes: pos.2 Rubber gasket pos.3 Flange pos. 7 heating element 3000 W / 230 V, with thermostat + thermal cut out 70 ±5°C / 85 ±5°C with plug (MB3000 ORW1_230V-64)
	3 kW	Water heater set 3 kW (from 160 up to 500 L)	301455	Package includes: pos.2 Rubber gasket pos.3 Flange pos. 7 heating element 3000 W / 230 V 3 phase, L= 290 pos. 9 Thermostat + thermal cut out with thermo pocket (form 160 up to 500 L)
	4.5 kW	Water heater set 4.5 kW (from 160 up to 500 L)	301457	Package includes: pos.2 Rubber gasket pos.3 Flange pos. 7 heating element 4500 W / 230 V 3 phase, L= 405 pos. 9 Thermostat + thermal cut out with thermo pocket (form 160 up to 500 L)
	6 kW	Water heater set 6 kW (from 160 up to 500 L)	301458	Package includes: pos.2 Rubber gasket pos.3 Flange pos. 7 heating element 6000 W / 230 V 3 phase, L= 440 pos. 9 Thermostat + thermal cut out with thermo pocket (form 160 up to 500 L)
from 800 up to 2000 L	4.5 kW	Water heater set 4.5 kW (from 800 up to 2000 L)	300560	Package includes: pos. 7 HE 4500 W / 230 V 3 phase, L= 405 pos. 9 Thermostat + thermal cut out with thermo pocket (form 750 up to 2000 L)
		Kit Flange	300567	pos.2 Rubber gasket pos.3 Flange G1½"
	6 kW	Water heater set 6 kW (from 800 up to 2000 L)	300562	Package includes: pos. 7 HE 6000 W / 230 V 3 phase, L= 505 pos. 9 Thermostat + thermal cut out with thermo pocket (form 750 up to 2000 L)
		Kit Flange	300567	pos.2 Rubber gasket pos.3 Flange G1½"
	7.5 kW	Water heater set 7.5 kW (from 800 up to 2000 L)	300564	Package includes: pos. 7 HE 7500 W / 400 V 3 phase, L= 615 pos. 9 Thermostat + thermal cut out with thermo pocket (form 750 up to 2000 L)
		Kit Flange	300567	pos.2 Rubber gasket pos.3 Flange G1½"
	12 kW	Electrical heat resistance 12 kW 2" (from 800 up to 2000 L)	304313	Package includes: pos.2 Rubber gasket pos. 7 HE 12000 W / 400 V 3 phase, L=520, G2" pos. 9 Thermostat + thermal cut out with thermo pocket (form 750 up to 2000 L)
		Kit Flange	300568	pos.2 Rubber gasket pos.3 Flange G2"
Heating elements (separately delivered):				
from 160 up to 500 L	3 kW	Heating element P&P	300910	Heating element "Plug and play" 3000W / 230V
	3 kW	Electrical heat resistance 3 kW (from 160 up to 500 L)	300570	HE 3000 W / 230 V 3 phase, L= 290
	4.5 kW	Electrical heat resistance 4.5 kW (from 160 up to 2000 L)	300571	HE 4500 W / 230 V 3 phase, L= 405
	6 kW	Electrical heat resistance 6 kW (from 160 up to 500 L)	300572	HE 6000 W / 230 V 3 phase, L= 440
from 800 up to 2000 L		Combined temperature control unit	300592	Thermostat + thermal cut out with thermo pocket (form 160 up to 500 L)
	6 kW	Electrical heat resistance 6 kW (from 800 up to 2000 L)	300573	HE 6000 W / 230 V 3 phase, L= 505
	7.5 kW	Electrical heat resistance 7.5 kW (from 800 up to 2000 L)	300575	HE 7500 W / 400 V 3 phase, L= 615
	12 kW	Electrical heat resistance 12 kW (from 800 up to 2000 L)	300569	HE 12000 W / 400 V 3 phase, L= 520
		Combined temperature control unit	300593	Thermostat + thermal cut out with thermo pocket (form 800 up to 2000 L)

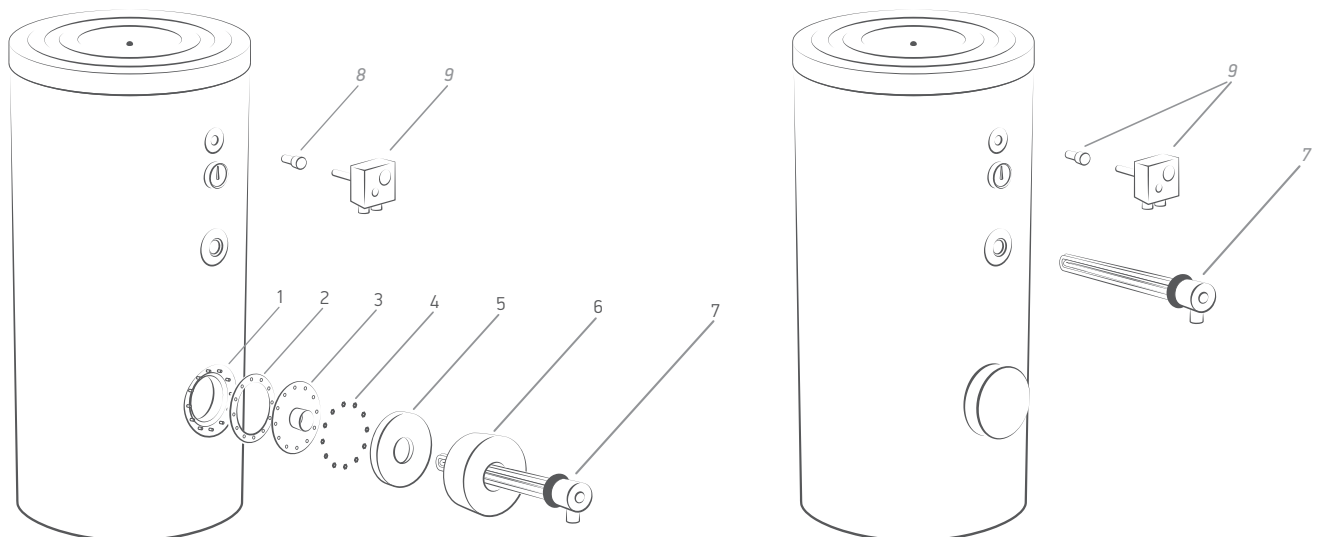

Ceramic Heating element

MODEL		CHE2400F	CHE4800R
Art. number		301667	301668
Rated Voltage and frequency		230 V / 50 Hz	230 V / 50 Hz
Rated power	W	2400	4800
Rated current	A	10.4	20.8
Used with storage tanks with a capacity	L	160, 200, 300, 400, 500	160, 200, 300, 400, 500
IP code		IPx4	IPx4
Temperature range		with fixed thermostat at 65°C	with thermostat from 5 to 65°C
Dimensions (flange Ø / length)	mm	180 / 540	180 / 540

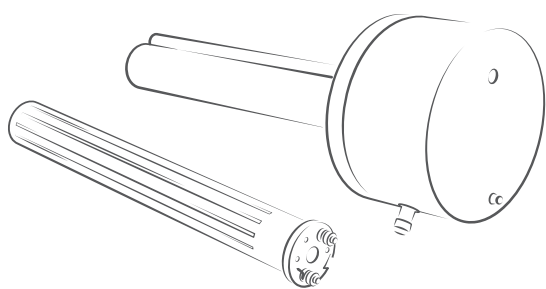
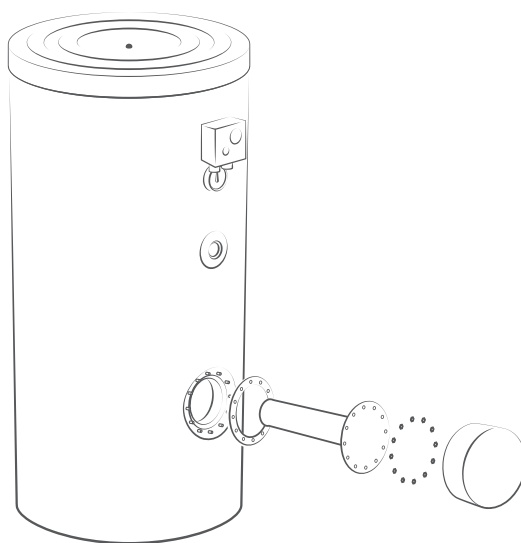

CHE 2400 F

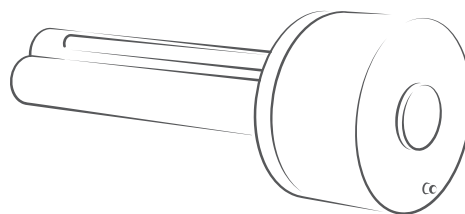

CHE 4800 R

Solar thermal sets



MODEL		SP 08 200 CSL	SP 08 260 CSL
Art.number		421600	421602
Absorber area	m ²	1.80	2.37
Weight empty	kg	36.5	45
Coating		selective	selective
Absorption ratio	%	95	95
Reflection capacity	%	5	5
Max. operating pressure	bar	10	10
Number of risers	pieces	8	11
Heat carrier		propylene-glycol solution	propylene-glycol solution
Absorber capacity	L	1.28	1.64
Attachment connections	mm	Ø 22	Ø 22
Collector efficiency (absorber)	%	77	78
Heat loss linear ratio a ₁	W/m ² K	3.95	3.77
Heat loss square ratio a ₂	W/m ² K ²	0.016	0.015
Dimensions	L	mm	2030
	W	mm	1030
	H	mm	80

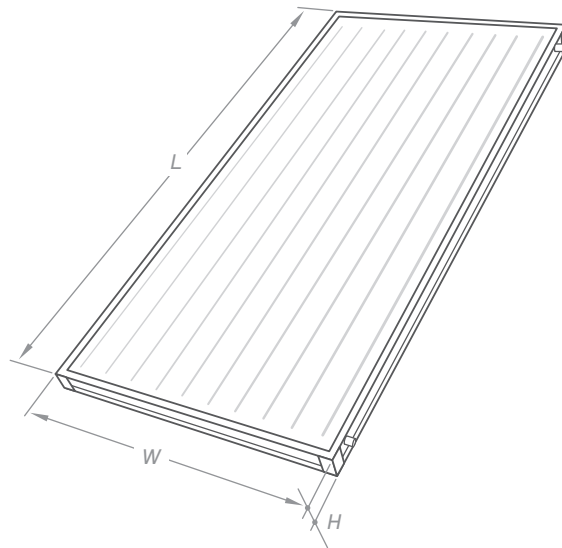

SP 08 200 CSL - Pressure drop

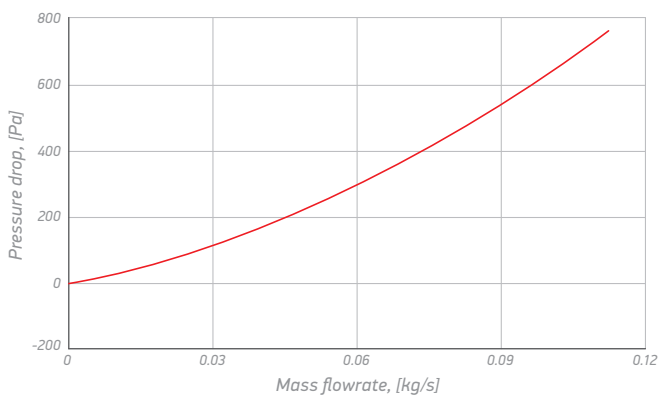

SP 08 260 CSL - Pressure drop

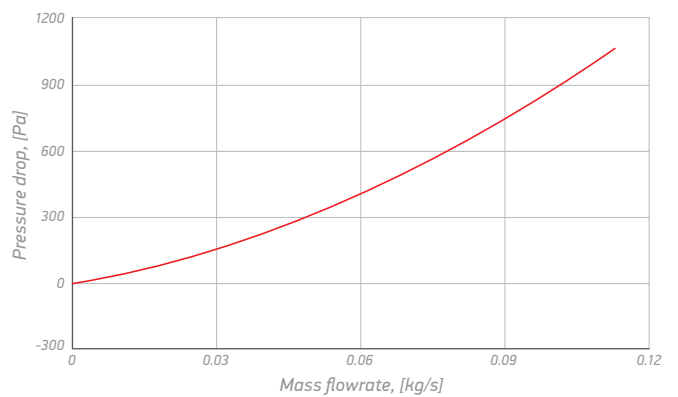

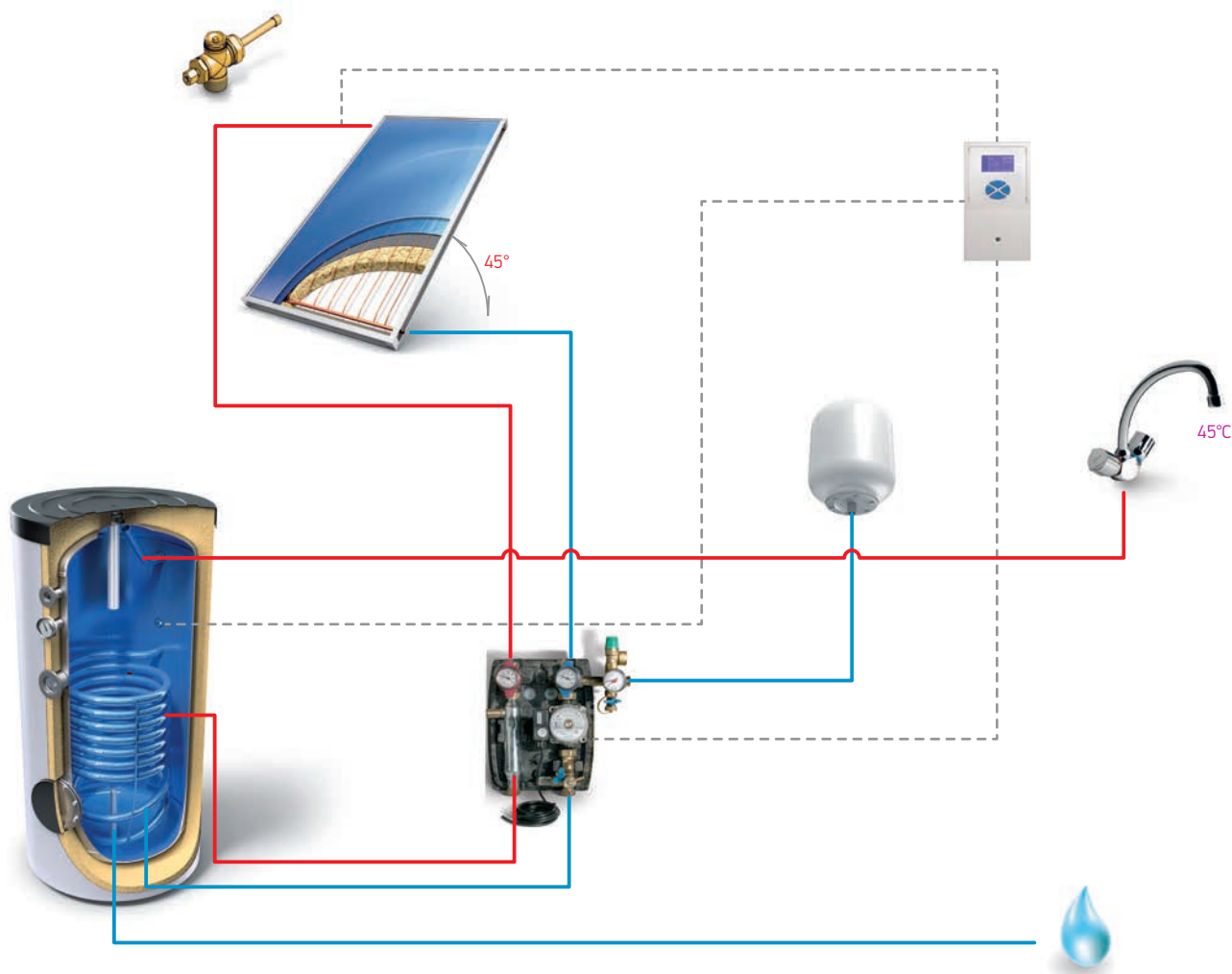

MODEL		SS 150 SP08	SS 200 SP08	SS 300 SP08	SS 500-6 SP08
Art. number	Nº	301673	301675	301676	301677
Number of people served		2-3	3-4	4-5	6-7
Maximum available amount of hot water	L	147	225	330	553
Solar panel type		1 x SP 08 200 CSL	2 x SP 08 200 CSL	2xSP08 200 CSL	3xSP08 200 CSL
Solar storage tank model		EU GCV9S 150 44 20 B11 TSRP	EV 7/5S2 200 60 F40 TP2	EV 10/7S2 300 65 F41 TP2	EV 15/7S2 500 75 F42 TP2
Pump group model		FlowBox 8010-S	FlowBox 8010-S	FlowBox 8010-S	FlowBox 8010-E
Expansion vessel		S12L	S12L	S12L	S24L
Controller model		RS02P	RS02P	RS02P	ECOSOL-E
Propylene glycol - 5 L	pieces	1	2	3	3
Solar stand		1 x MK-SR/FR-SP08	1 x MK-SR/FR-SP08 200 Double	1 x MK-SR/FR-SP08 200 Double	1 x MK-SR/FR-SP08 1 x MK-SR/FR-SP08 200 Double
Input-output connections		1 x Manual air vent 2 x Cap 22 mm 1 x Nipple Ø 22-¾"	1 x Manual air vent 2 x Cap 22 mm 1 x Nipple Ø 22-¾" 2 x Nipple Ø 22-Ø 22	1 x Manual air vent 2 x Cap 22mm 1 x Nipple Ø 22-¾" 2 x Nipple Ø 22-Ø 22	1 x Manual air vent 2 x Cap 22mm 1 x Nipple Ø 22-¾" 2 x Nipple Ø 22-Ø 22 2 x Flexible hose 4 x Nipple Ø 22-1"
Package set dimensions (L x W x H)	mm	820 x 1280 x 2460	820 x 1280 x 2460	1200 x 1280 x 2460	1200 x 1280 x 2460

All systems are designed for latitude between ~ 35°N to 50°N and altitude between ~ 0 m to 1000 m!
For more details about system design, please refer to instruction manual!



NAME		Art. number						
Expansion vessel - In conformity with Pressure equipment directive 97/23EC (PED), module H1								
	S 12 L	421170	Capacity	Height	Diameter	Connection	Max working pressure	Max working temperature
	S 24 L	421171	12 L	350 mm	270 mm	3/4"	10 bar	130°C
			24 L	460 mm	270 mm	3/4"	10 bar	130°C
Solar controller - Digital control system for the management of solar heat plant								
	ECOSOL-E	422366	Dimensions	Description				
	PT1000		163x110x52 mm	Programmable digital control system for solar thermal installations including solar collectors, circulation pumps, and/or diverter valves, storage tanks and integrative heating. In addition to the basic function of control temperature differential regulator, it features numerous options and advanced features to manage plant layouts of various complexities and to optimize the overall performance of the plant; it allows achieving considerable energy savings thanks to the ability to drive pumps with high efficiency and to manage flow sensors.				
	NTC		-	<ul style="list-style-type: none"> - universal power supply - graphic backlit LCD - two-colour LED for diagnostics/signalling - 3 touch keys with sound feedback - 4 inputs for PT1000 or NTC probes - 1 input for flow meter - 4 relay outputs of which 2 PWM outputs - SELV insulation - it can be mounted on the wall or in an electric control panel 				
	RS02P	422364	Dimensions	Description				
	PT1000		100x70x36 mm	Programmable digital controller for solar thermal systems equipped with a solar collector, a high-efficiency circulation pump, a storage tank and heating support. Besides its basic function of temperature differential regulator, this device is able to optimize the solar thermal system performance thanks to the possibility to drive a PWM modulating pump, and it also offers several functions for the system protection. Its potentialities, as well as its simple design and user-friendly interface, make this product suitable for different types of solar thermal systems.				
	NTC		-	<ul style="list-style-type: none"> - 2-digit 7-segment display - 3 diagnostics/signalling LEDs - 3 set-up keys - 3 inputs for probes type PT1000 or NTC (10K@25°C b=3435 or 1,65K@80°C b=3530) - 3 outputs: - 1 (power-free contact) N.O. relay output - 1 (12VDC) PWM output + 1 associated (mains voltage) N.O. relay output - insulation type SELV (Safety Extra Low Voltage) - possible mounting on a wall or on an electric control panel 				
Solar pump group								
	FlowBox Solar FSB8010-S	420103	Dimensions	Max working pressure	Max working temperature	Debit range		
			308x270x220 mm	10 bar	110°C	2-16 L/min		
			Description					
			Ready-to mount, compact solar return. Pump installation length 130 mm- wired ex works, balancing valve WattFlow with fill and drain-cook, safety unit with pressure gauge, solar safety relief valve 6 bar and fill and drain-cook, wall bracket including corrugated tube to connect with the expansion vessel with, arrangeable metal gravity flow stop. EPP heat insulation. Compression fitting connection 22 mm.					
	FlowBox Solar FSB8010-E	422365	Dimensions	Max working pressure	Max working temperature	Debit range		
			308x250x200 mm	10 bar	110°C	4-36 L/min		
			Description					
			Ready-to-mount, compact solar control unit. Pump installation length 130 mm- wired ex works, balancing valve WattFlow with fill and drain-cook, safety unit with pressure gauge, solar safety relief valve 6 bar and fill and drain-cook, wall bracket including corrugated tube to connect with the expansion vessel with, arrangeable metal gravity flow stop. EPP heat insulation. Venting pipe. Compression fitting connection 22 mm.					

Caution! Pressure and temperature should be kept within the limits shown in the adjacent diagram. Avoid temperatures higher than 100°C during continuous operation! In short-term operation (2 h) to +120°C.

NAME		Art. number	
Connector and fitting for solar collector			
	Blind plug Ø 22	420100	Connection Ø 22
	Nipple Ø 22-Ø 22	420099	Ø 22 - Ø 22
Connection kit for one solar collector			
	Nipple NP-22-3/4" (Ø 22-3/4") 1 pcs	300876	Connection Ø 22 - G3/4"
	Blind plug Ø 22 2 pcs		Ø 22
	Manual air valve with sensor hive SH-22 1 pcs		Ø 22 - 3/4"
Flexible house kit FH-22 for solar panels			
	Flexible hose 50 mm 2 pcs	300877	Connection 1"
	Nipple NP-22-1" 4 pcs		Ø 22 - 1"
Roof set			
	MK-SRFR-SP08 Mounting kit for single solar panel SP08 200 / 260	421603	Description They are sent totally packaged, encoded and with installation manual.
	MK-SRDR-SP08 200 Double Mounting kit for two solar panels SP08 200 CSL	421606	Available for: - Flat and slope roofs for one solar panel SP08 xxx CSL: Model MK-SRFR-SP08 - Flat and slope roofs for two solar panels SP08 200 CSL: Model MK-SRDR-SP08 200 Double - Flat and slope roofs for two solar panels SP08 260 CSL: Model MK-SRDR-SP08 260 Double
	MK-SRFR-SP08 260 Double Mounting kit for two solar panels SP08 260 CSL	421605	
PG concetrate			
	Monopropylene Glykol HP	421182	Description Non-toxic antifreeze fluid. It is supplied in packing - 5kg (concentrate). Antifreeze protection of Monopropylene Glykol HP (concentrate) -60°C. Antifreeze protection of mixture Monopropylene Glykol HP:Water (50:50) -30°C. Antifreeze protection of mixture Monopropylene Glykol HP:Water (34:66) -20°C.



TESY - The Professionals' Brand

Tesy OOD

Sofia Park, Building 16V, 2nd Floor
1166 Sofia, Bulgaria

tesy.com

This catalogue is a marketing material and it is not an offer.
For specific models, please ask your dealer.

Copyright © All Rights Reserved, v.1 2018 – TESI OOD

